

NOTES.

1. Use wool mulch or other approved mulch matting in areas prone to submergence.

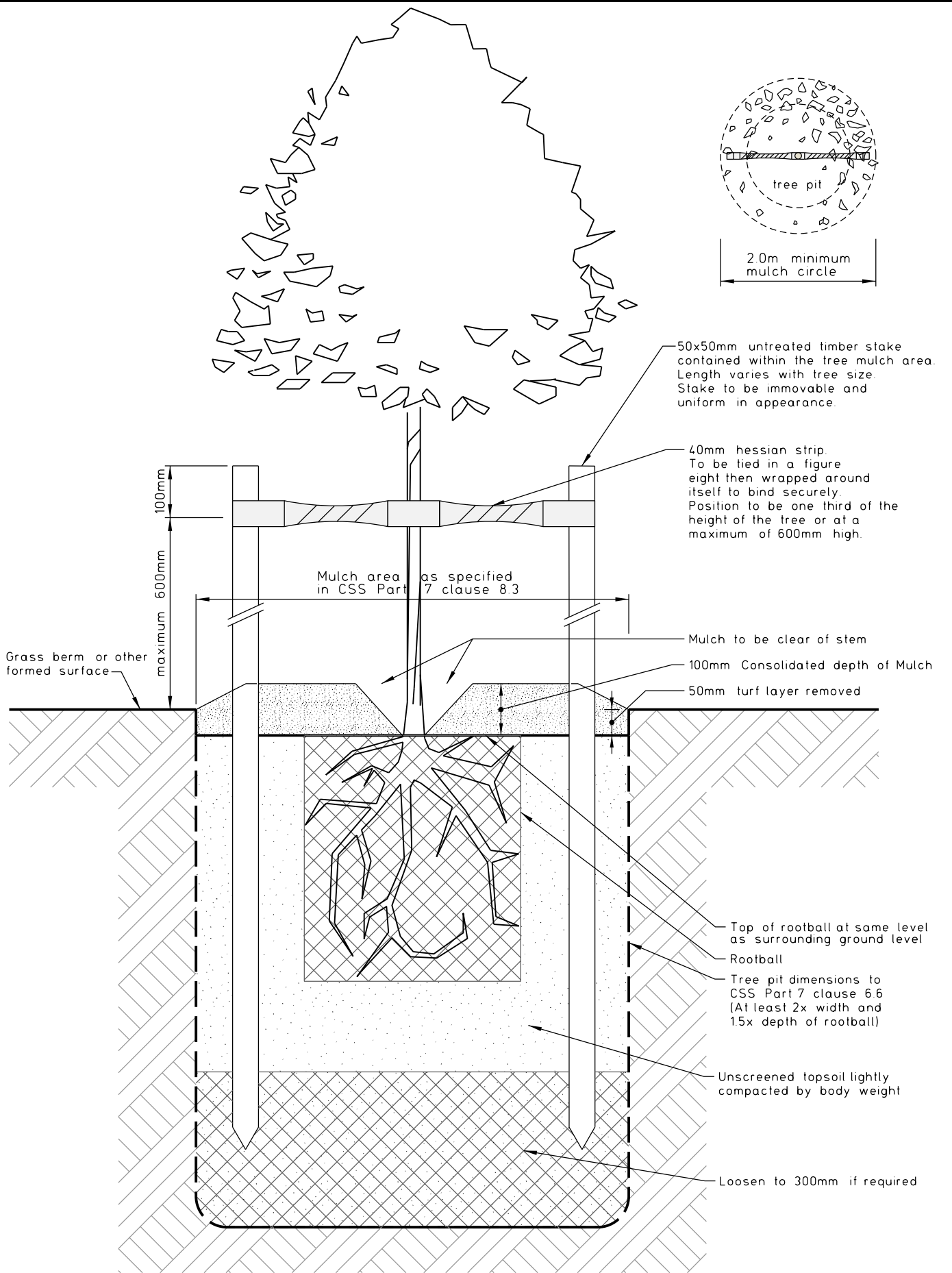

NOTES:

1. Disposal of all soil, grindings etc. from HAIL sites must be to specified sites.
2. Use wool mulch or other approved mulch matting in areas prone to submergence.

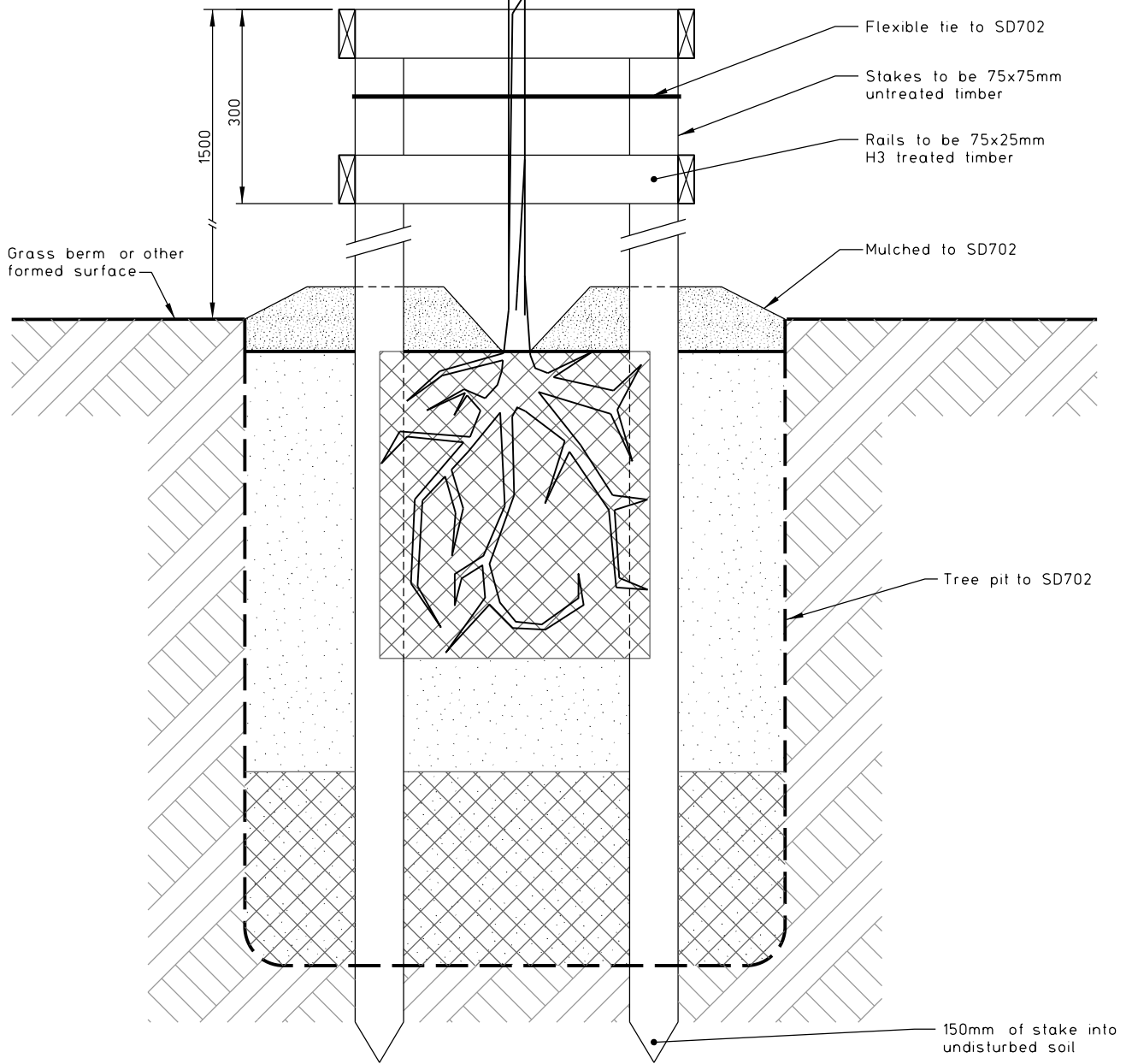
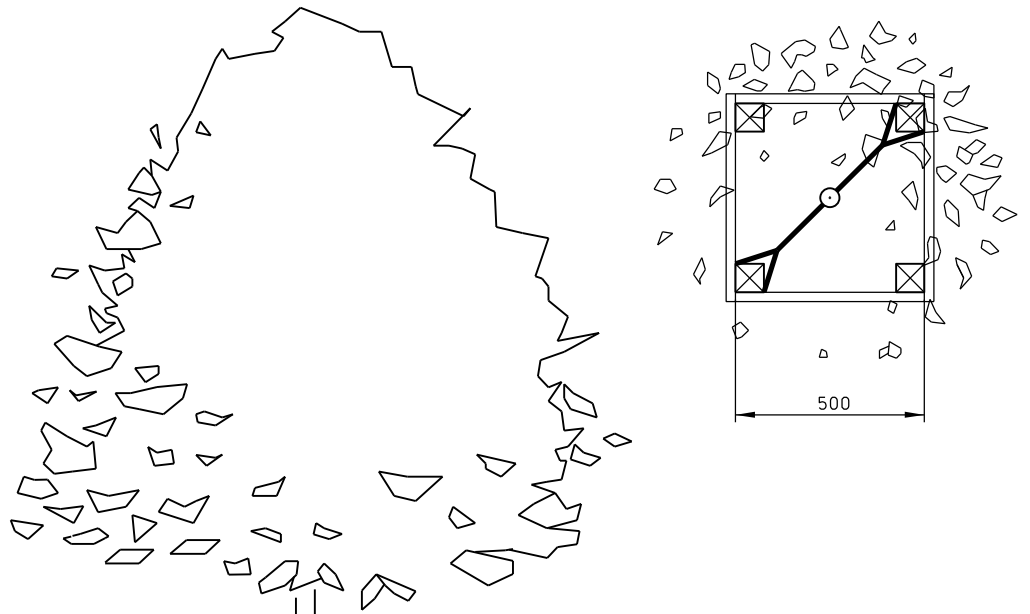

NOTES:  
1. For tree pit details see SD702

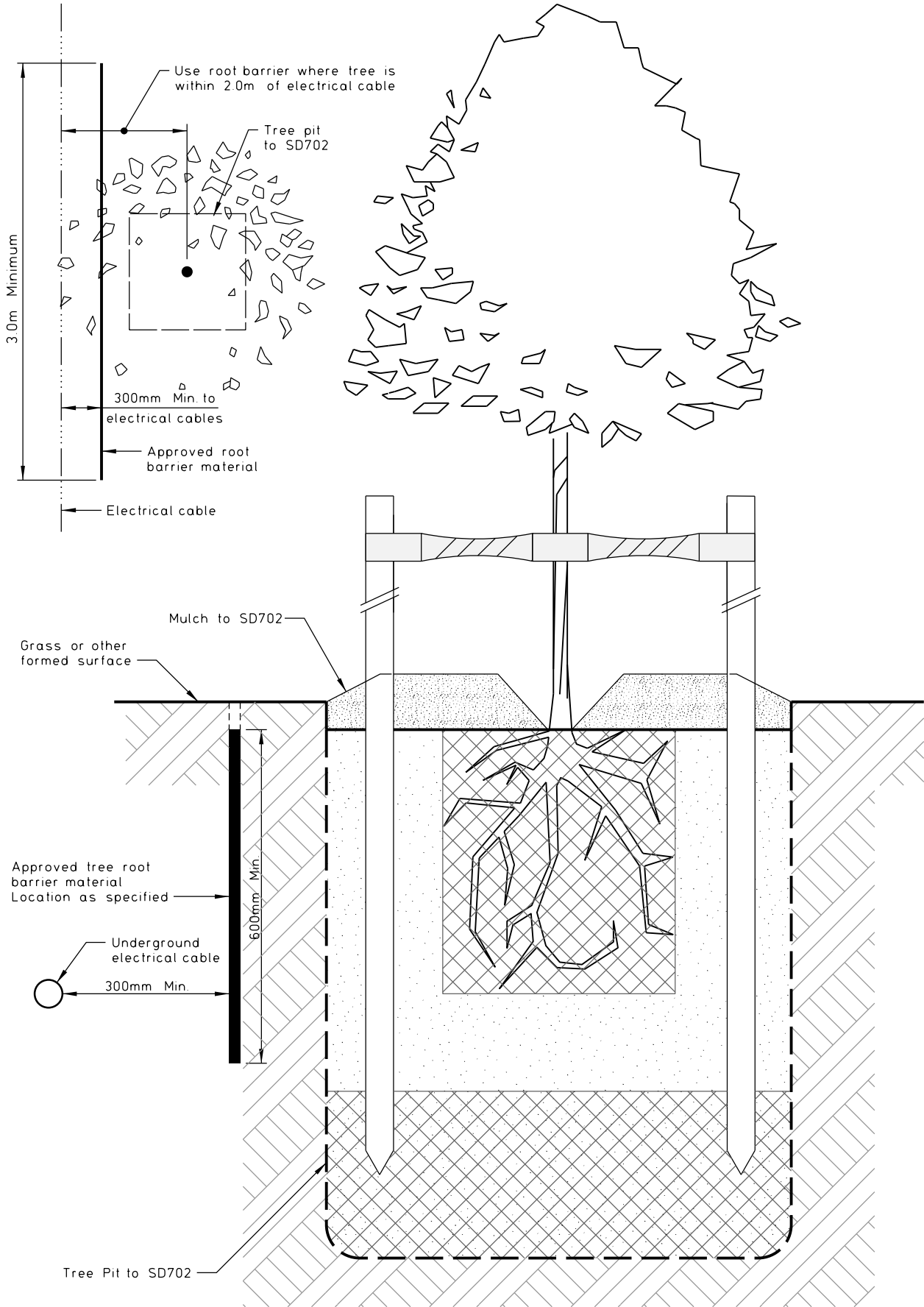

NOTES:

1. Only install root barrier where tree is adjacent to underground services.
2. Refer to CSS Part 7 clause 10.2 for requirements to protect electrical cables.

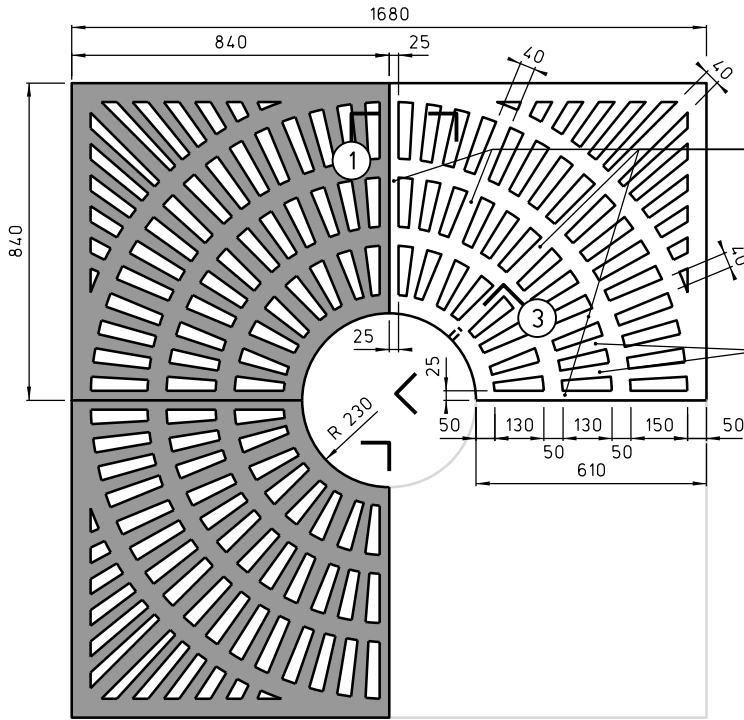

Main Spokes of equal thickness from outside edge through to centre

Tree grate to be cast iron in four sections and bolt fixed together around tree using galv. M16 bolts as detailed.

Sections between main spokes on radials & tapering thickness towards centre

② PLAN

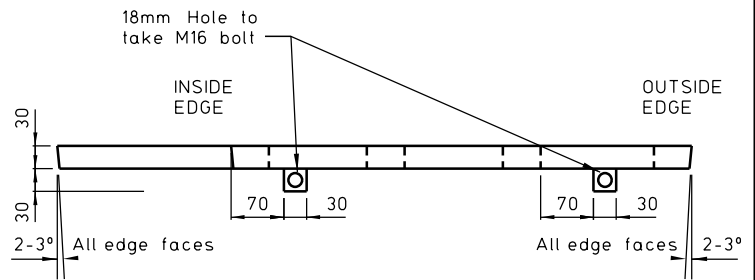
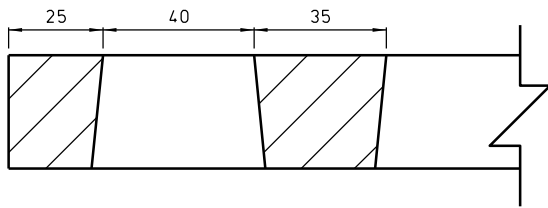

① CROSS SECTION

② TREE GRATE FIXING

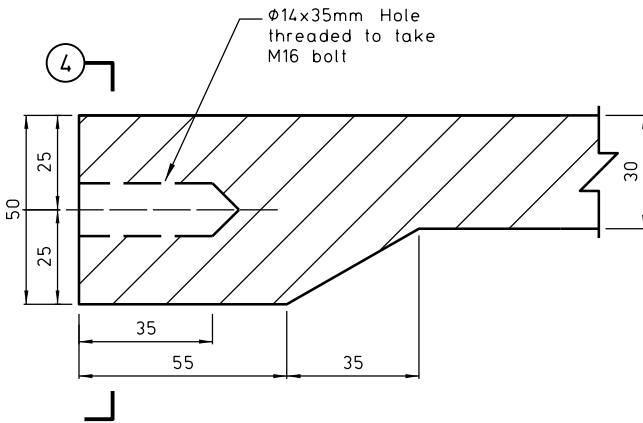

③ GUARD FIXING

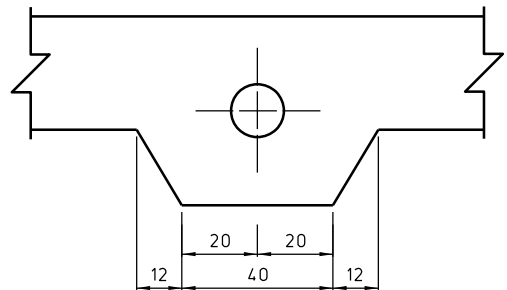

④ TREE GUARD FIXING

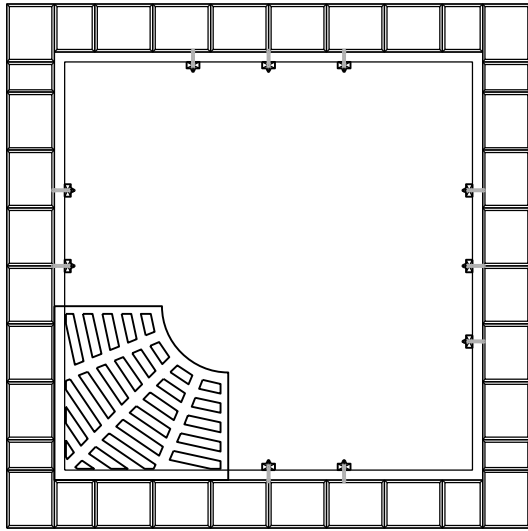

PAVER LAYOUT

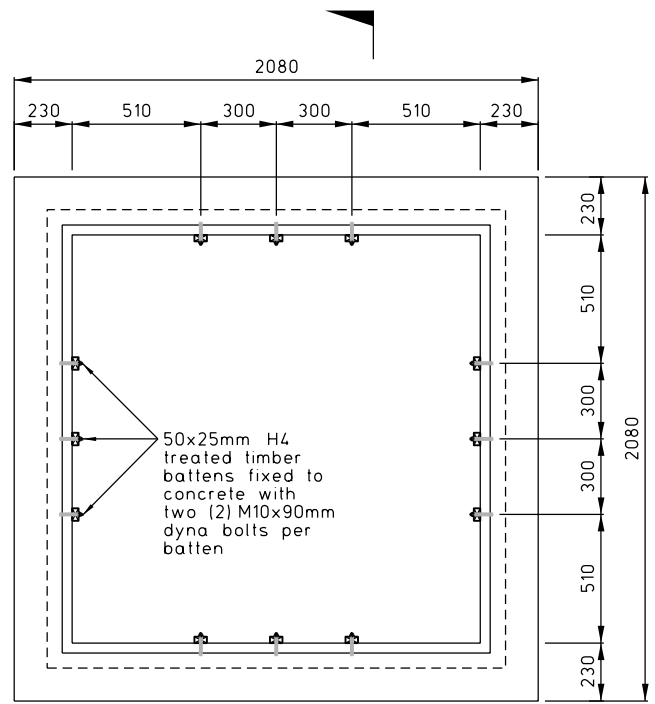

PLAN

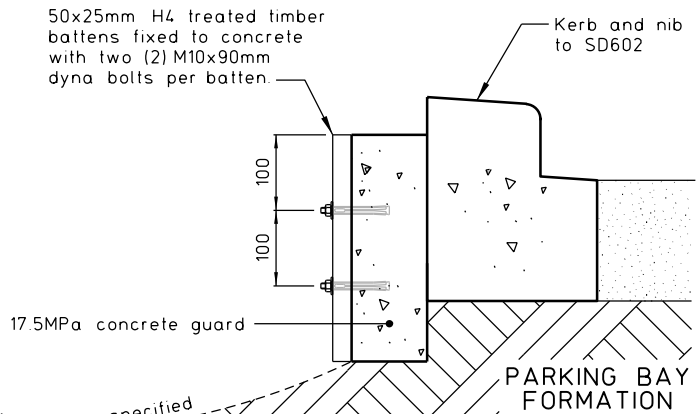
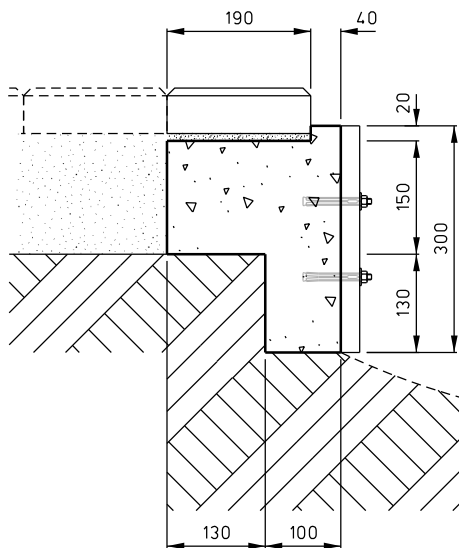

① CROSS SECTION

NOTES:

1. Use adjacent to parking areas / the roadway.

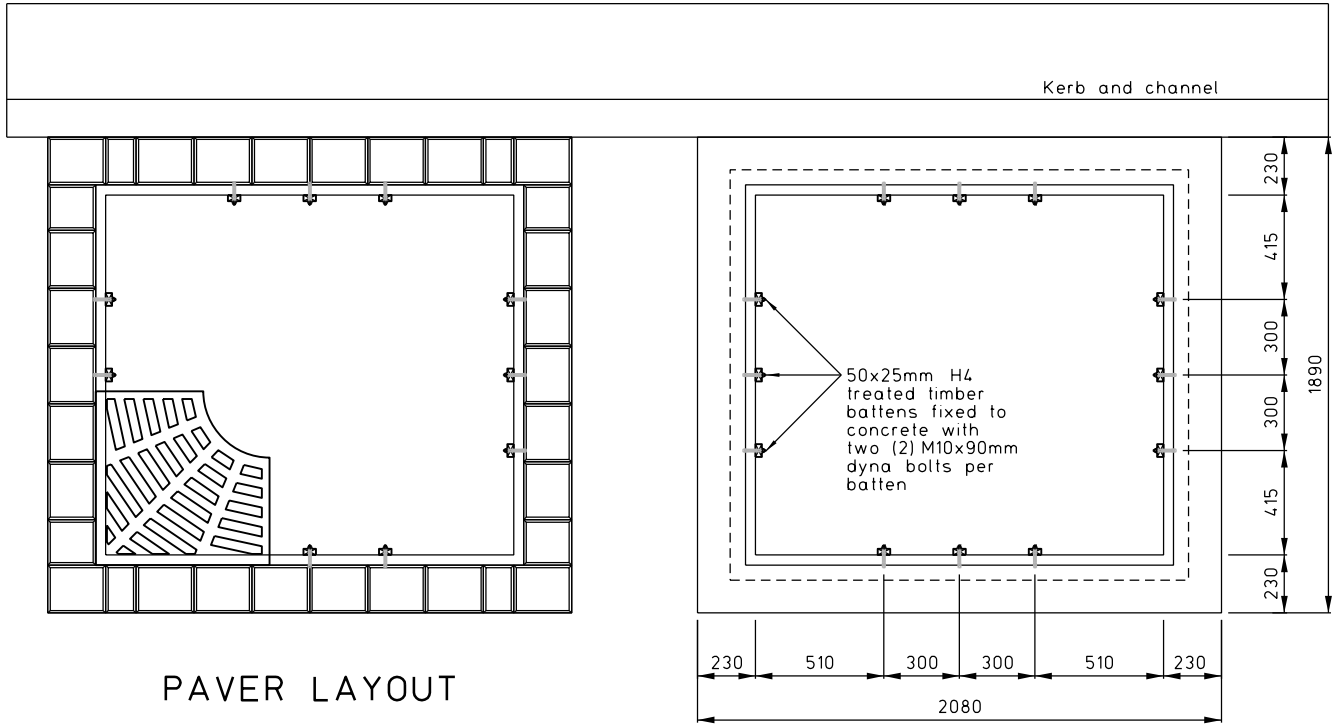

PAVER LAYOUT

PLAN

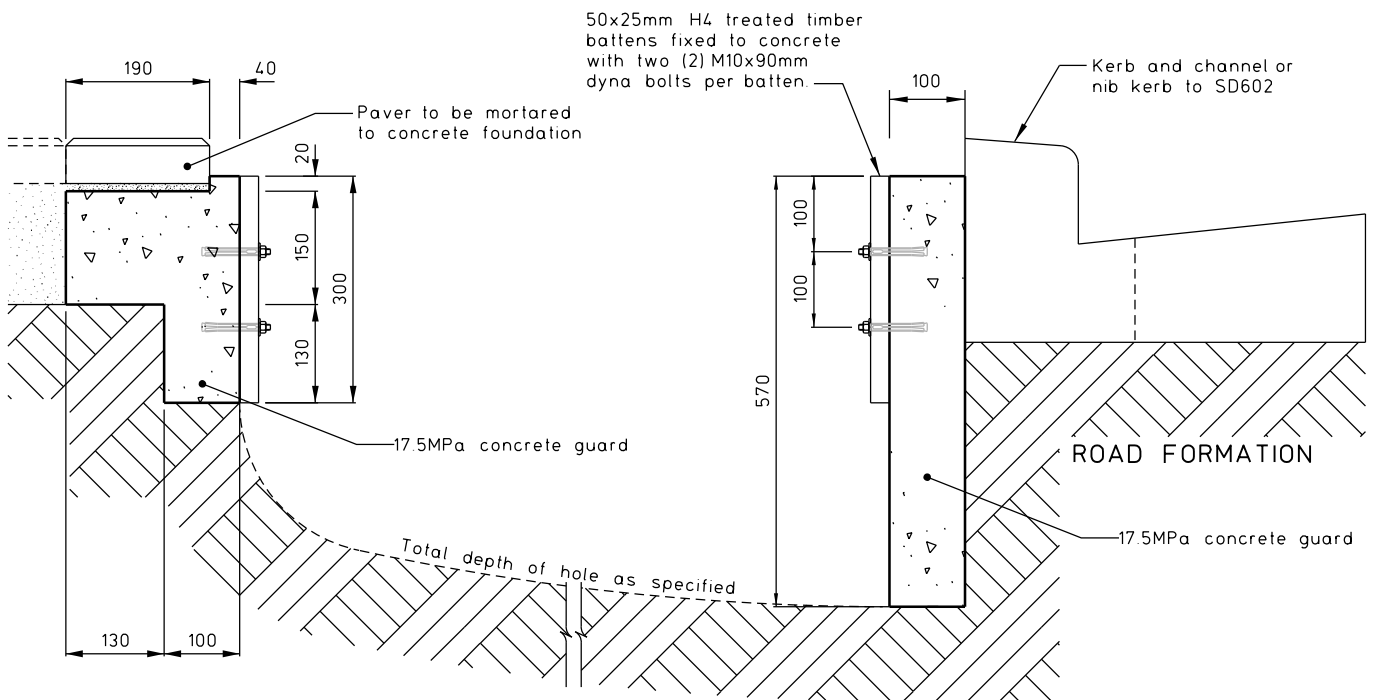

① CROSS SECTION

NOTES:

- 1. Use adjacent to parking areas / the roadway.

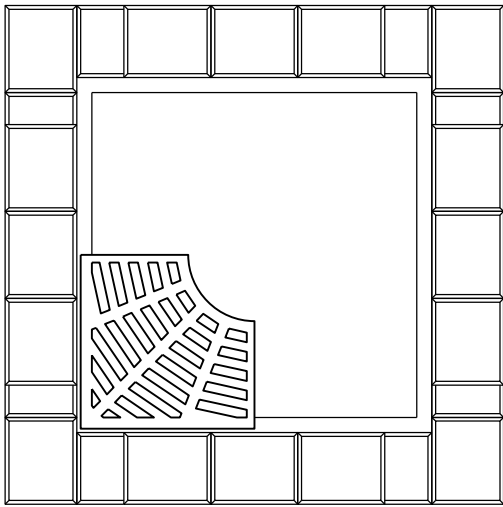

PAVER LAYOUT

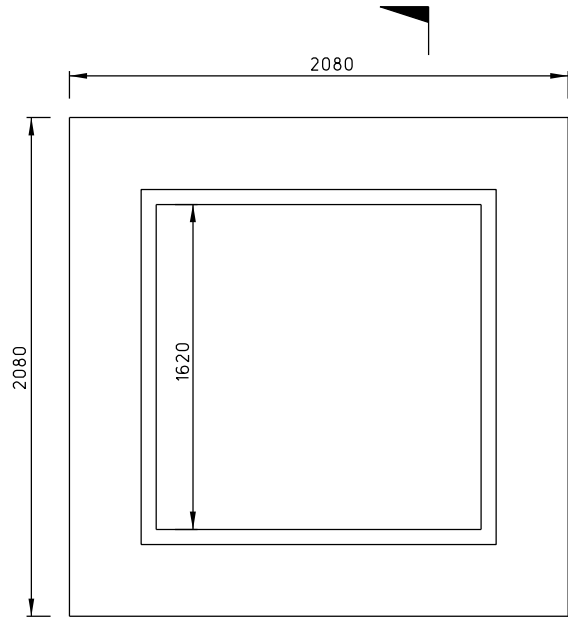

PLAN

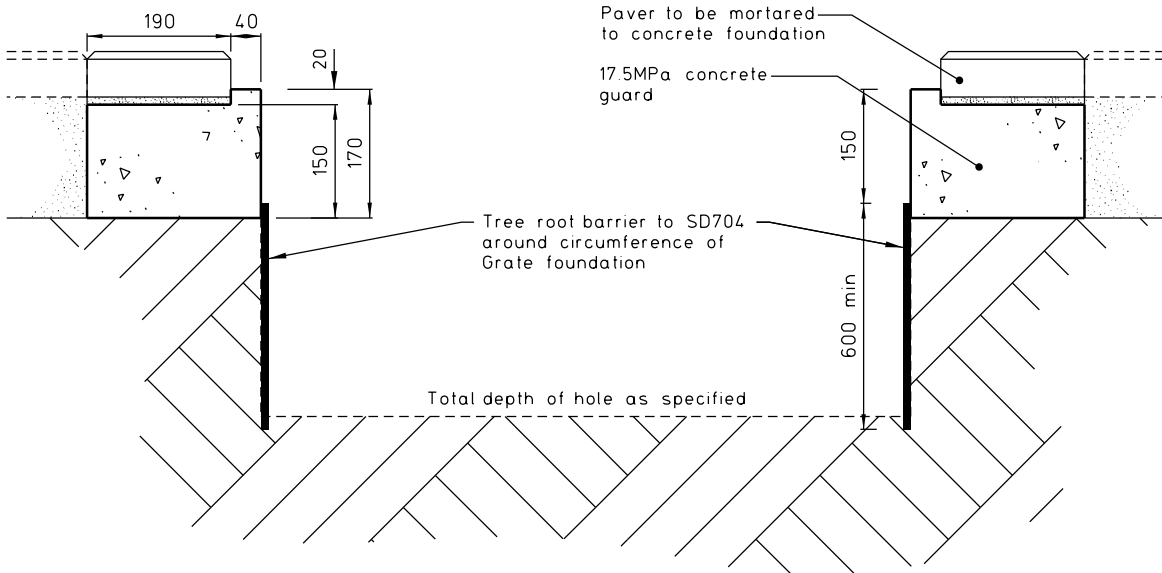

① CROSS SECTION



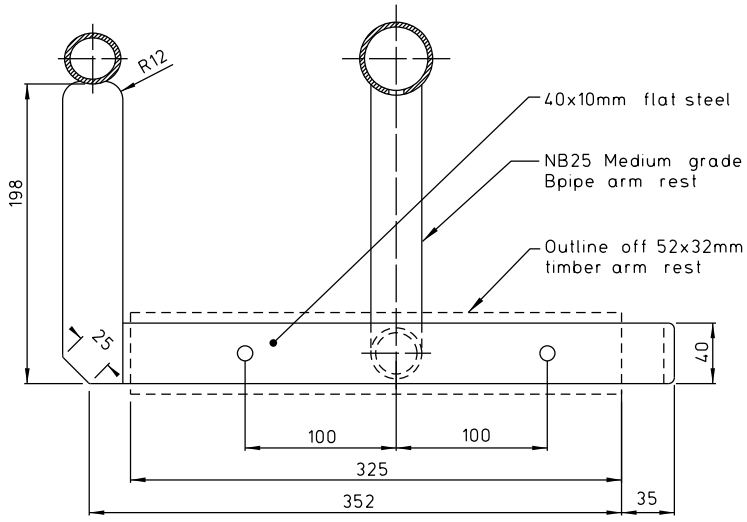

ARM REST PLAN

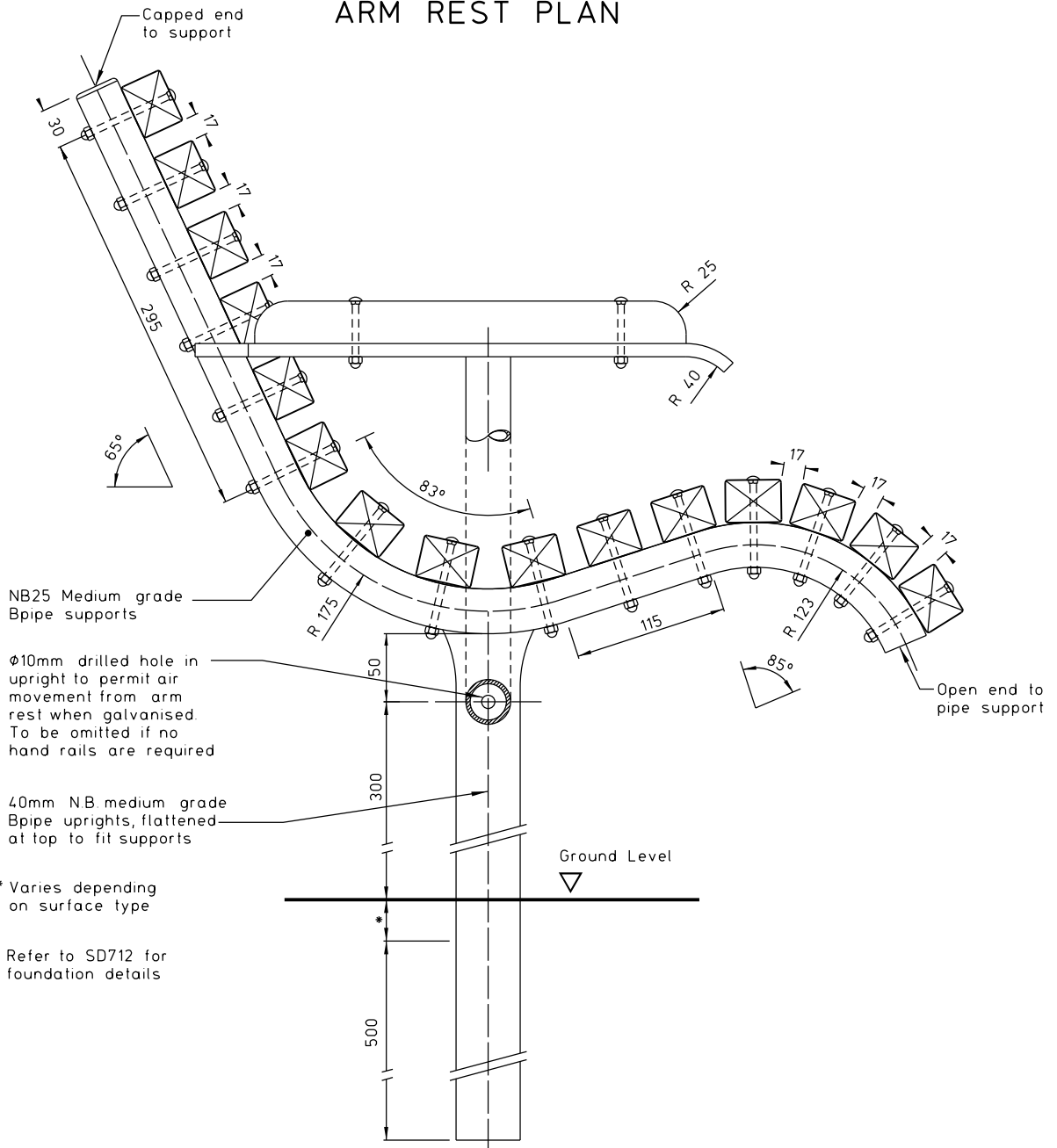

END ELEVATION

NB25 Medium grade Bpipe supports

Φ10mm drilled hole in upright to permit air movement from arm rest when galvanised. To be omitted if no hand rails are required

40mm NB medium grade Bpipe uprights, flattened at top to fit supports

\* Varies depending on surface type

Refer to SD712 for foundation details

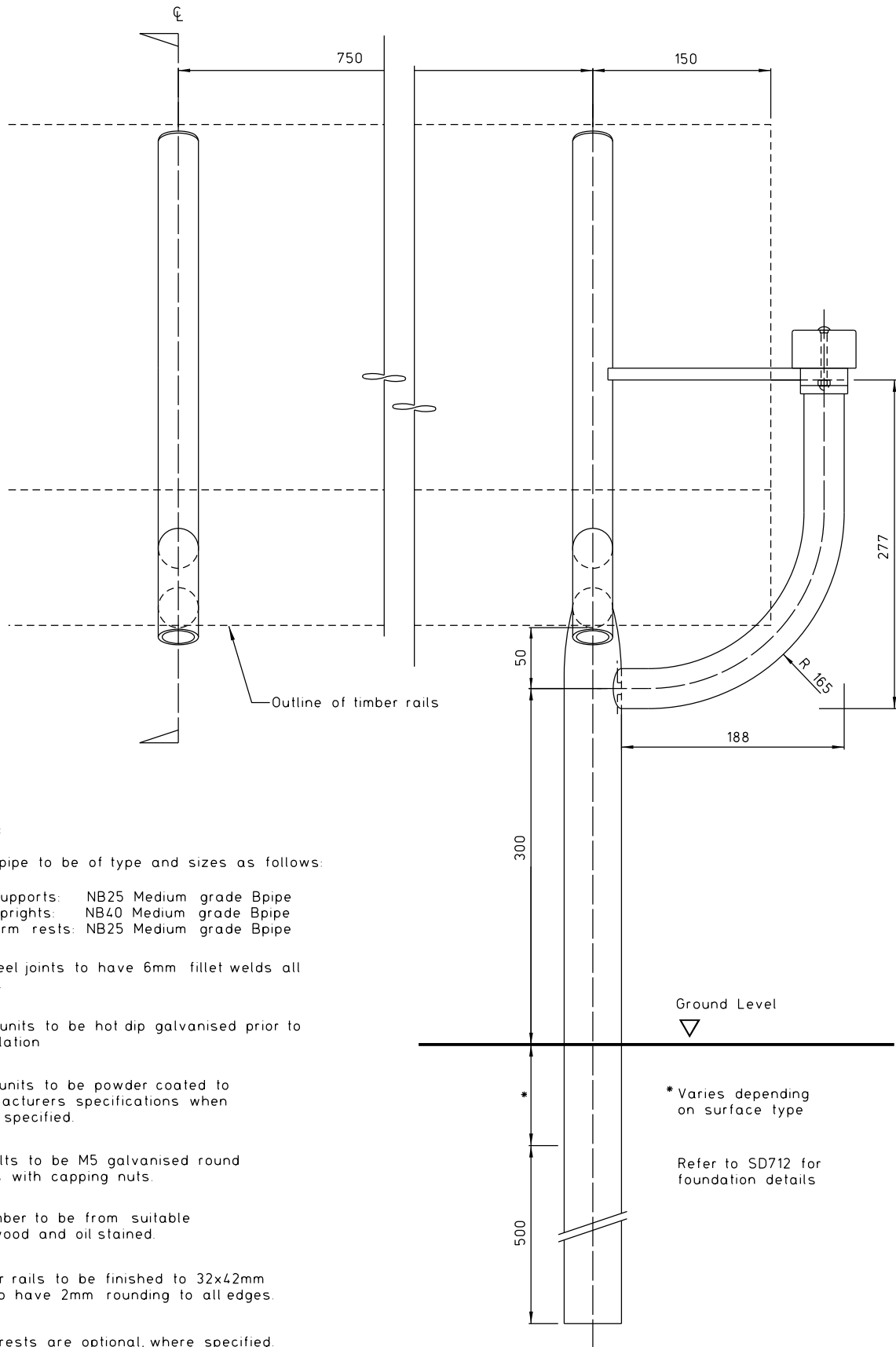

Notes:

1. Steel pipe to be of type and sizes as follows:
  - Supports: NB25 Medium grade Bpipe
  - Uprights: NB40 Medium grade Bpipe
  - Arm rests: NB25 Medium grade Bpipe
2. All steel joints to have 6mm fillet welds all round.
3. Steel units to be hot dip galvanised prior to installation
4. Steel units to be powder coated to manufacturers specifications when & as specified.
5. All bolts to be M5 galvanised round heads with capping nuts.
6. All timber to be from suitable hardwood and oil stained.
7. Timber rails to be finished to 32x42mm and to have 2mm rounding to all edges.
8. Arm rests are optional, where specified.
9. Timber arm rests to be finished to 52x32mm and to have 2mm rounding to all edges

Ground Level

\*Varies depending on surface type

Refer to SD712 for foundation details

HALF FRONT ELEVATION

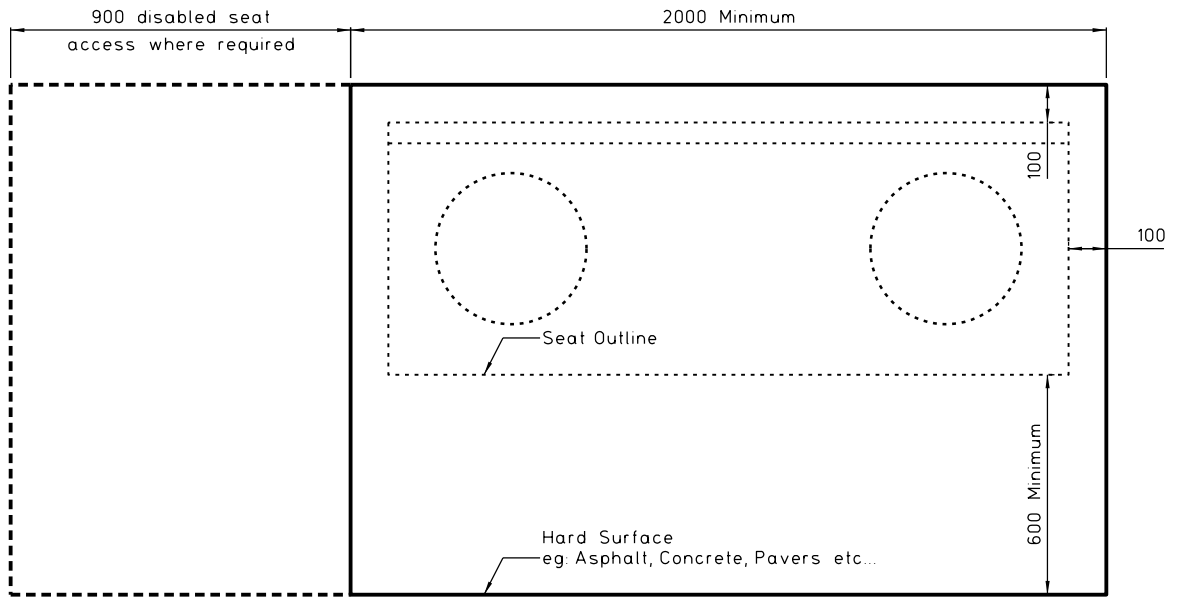

FOUNDATION PLAN

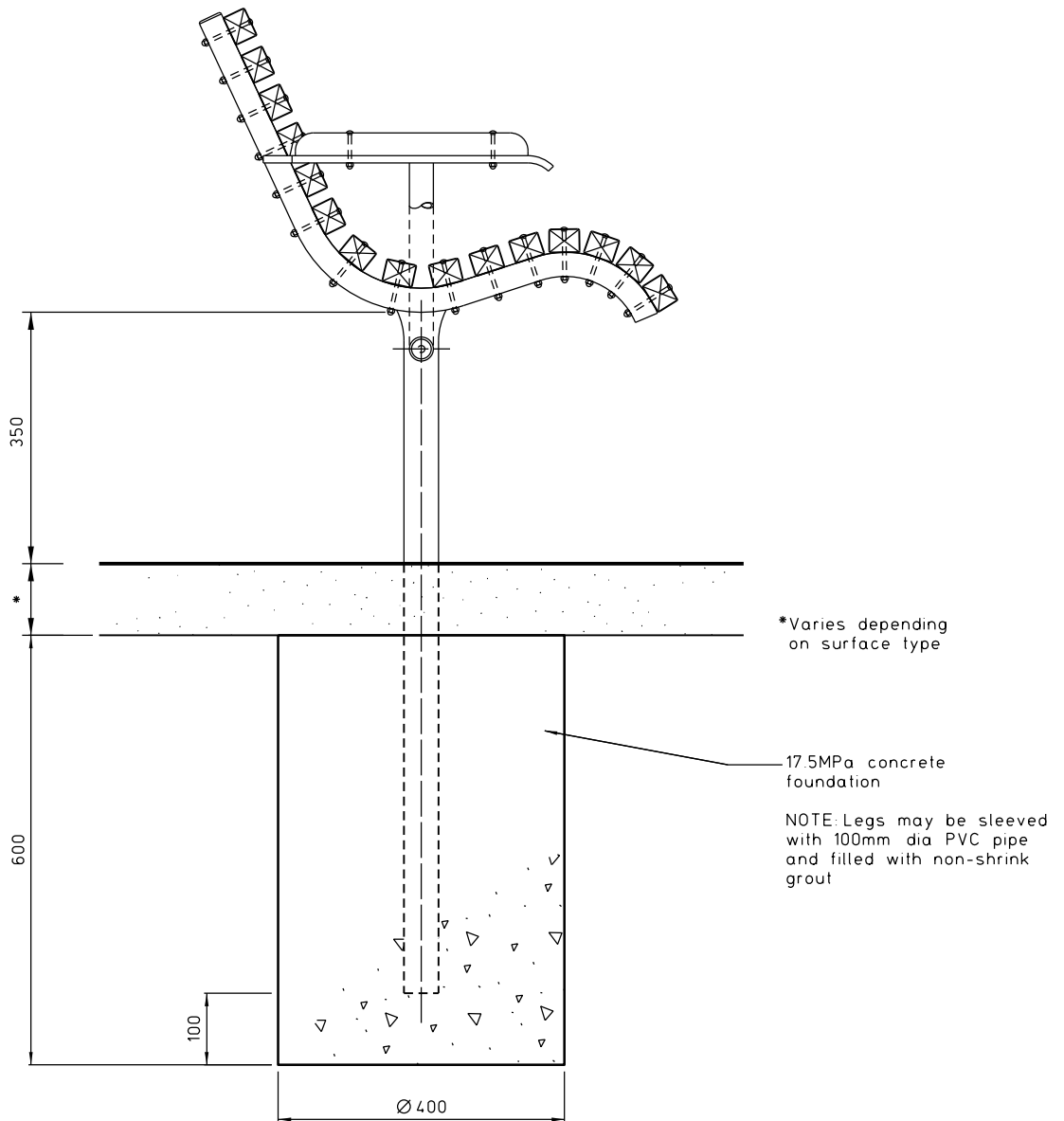

FOUNDATION DETAIL

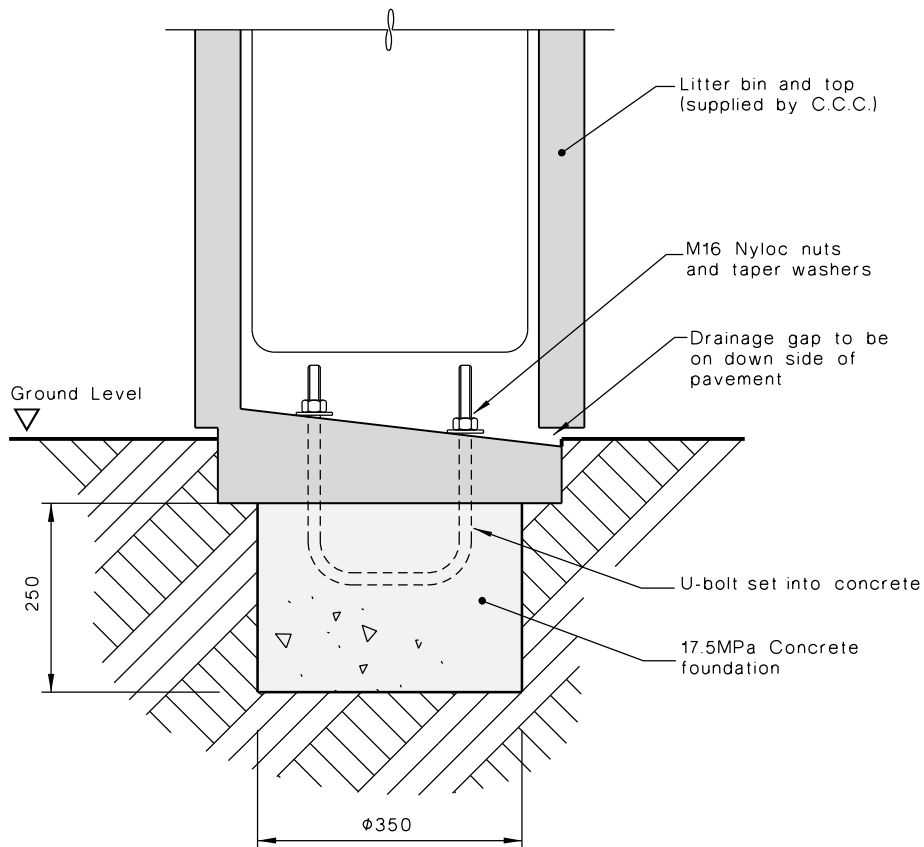
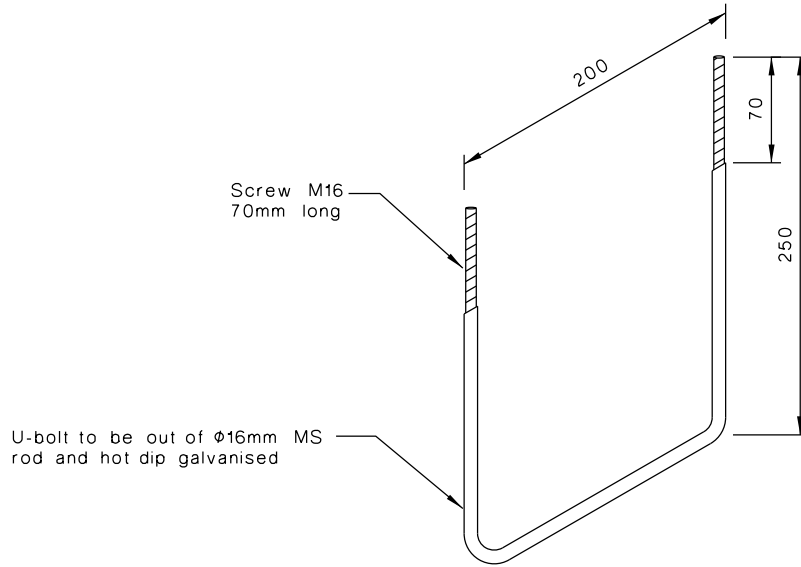

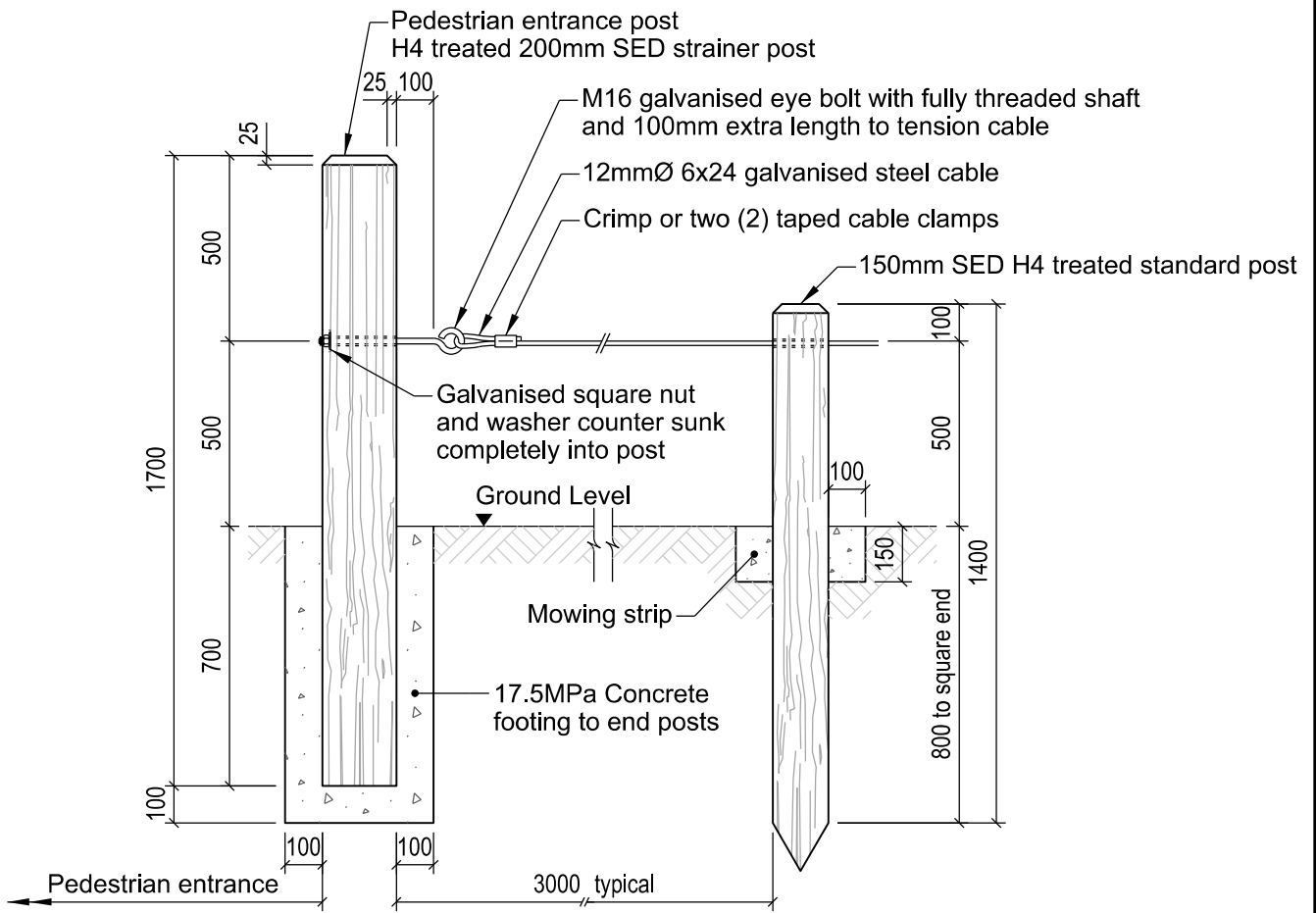

### Pedestrian Entrance

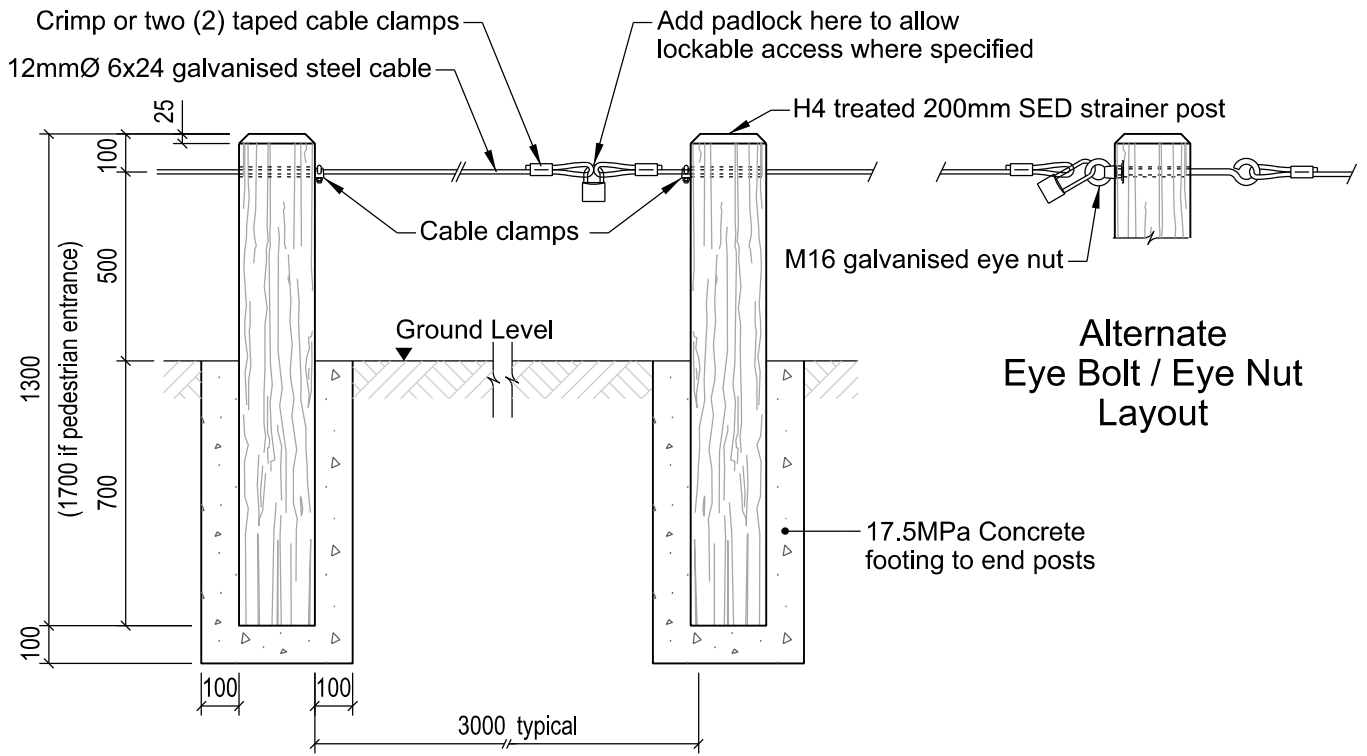

### Vehicle Entrance

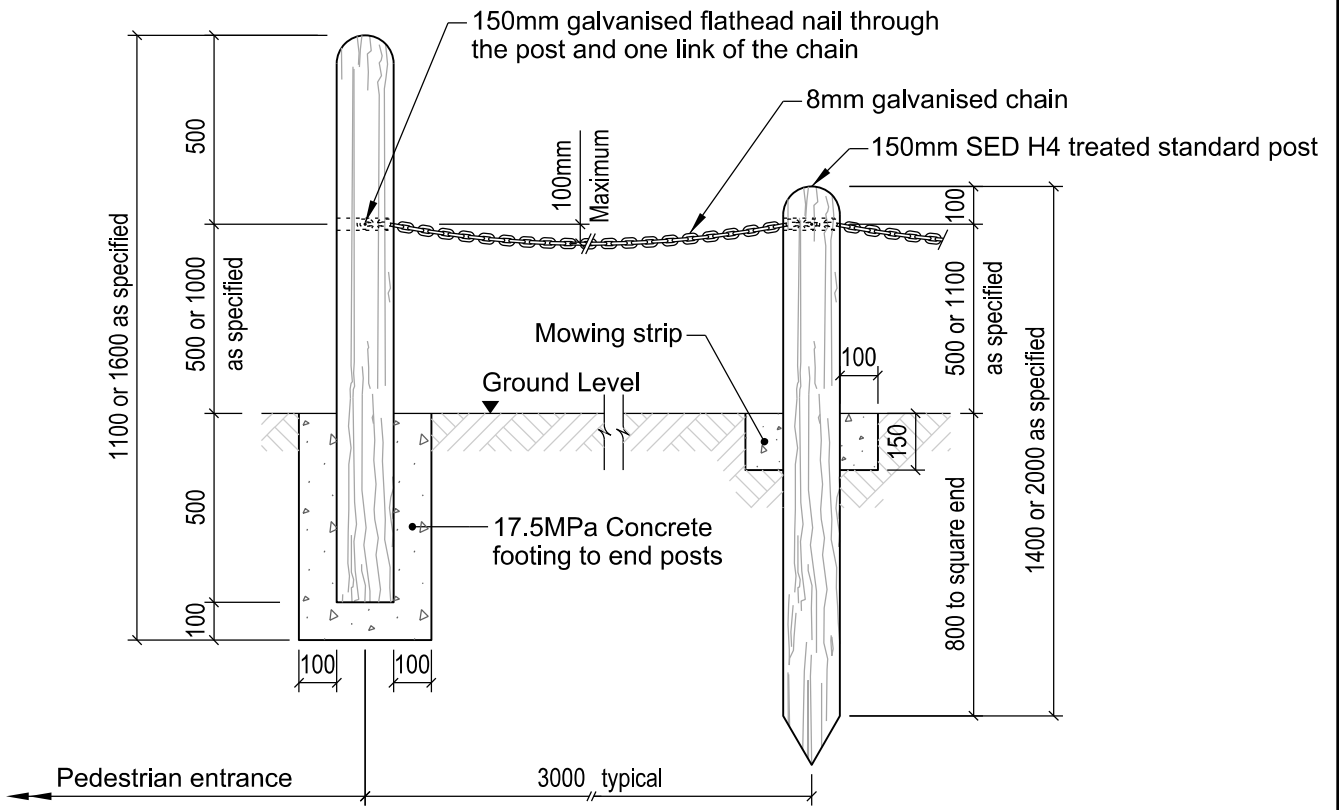

Pedestrian Entrance

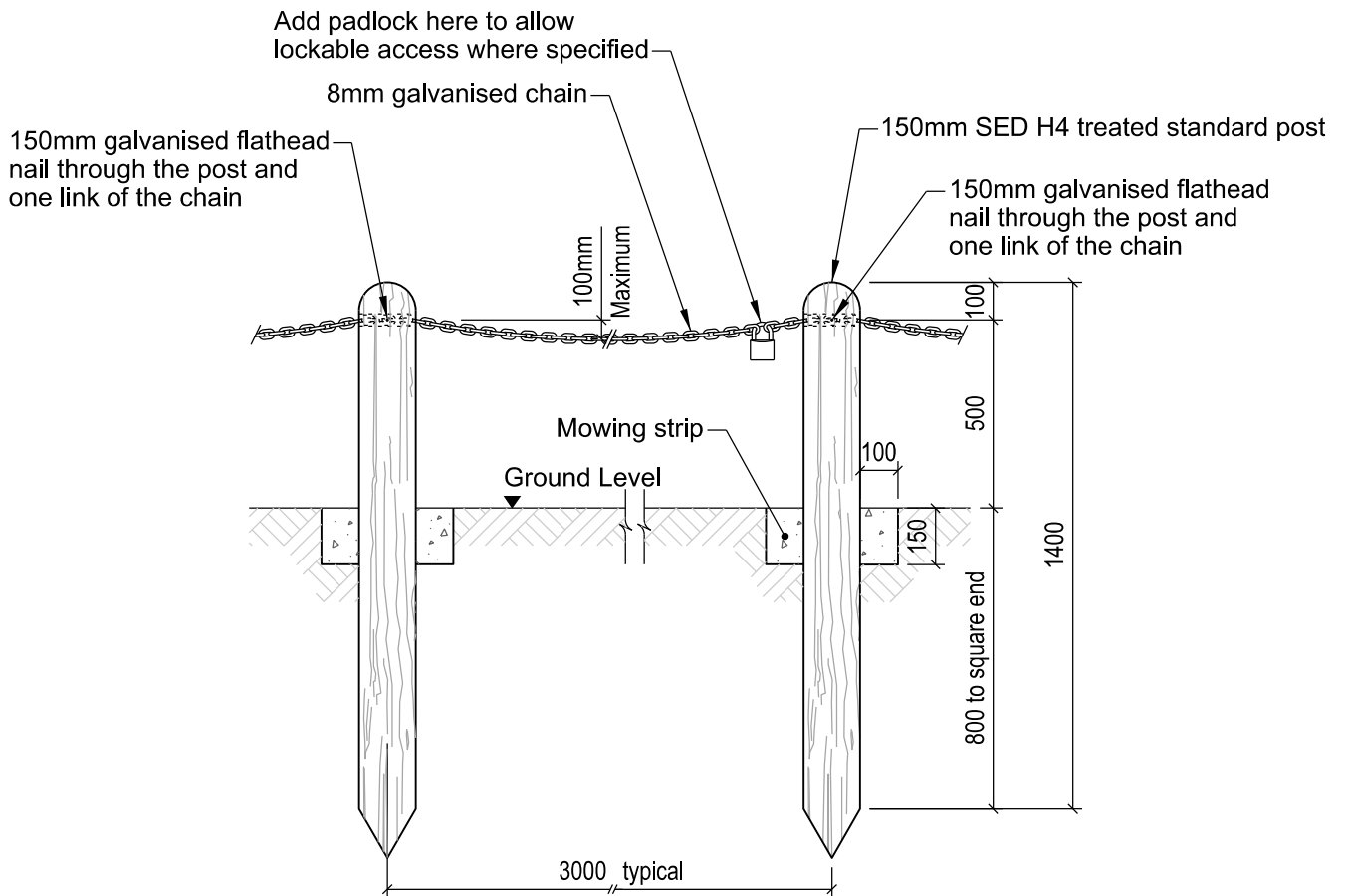

Vehicle Entrance

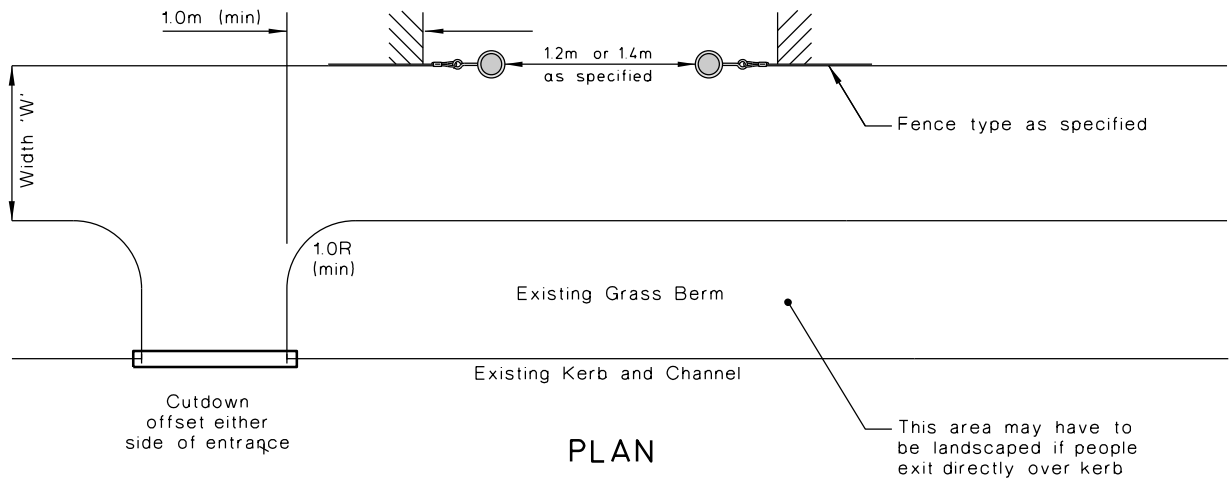

\* Cutdown NOT to be offset if:  
 (a) Low traffic volumes (<500 vehicles/day)  
 (b) High cycle numbers (>20 cyclists/any one hour)  
 (c) Width 'W' < 2.0m

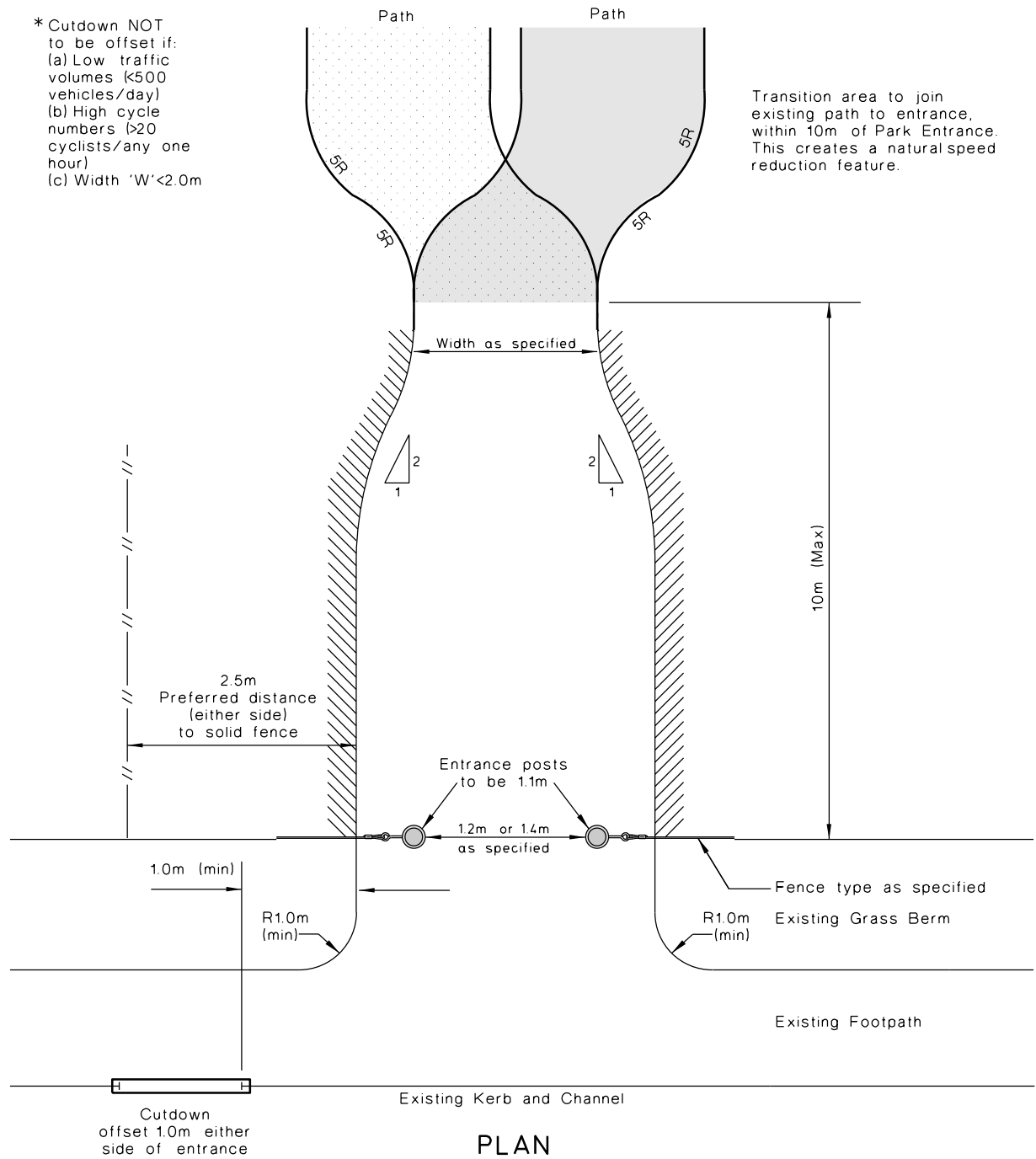

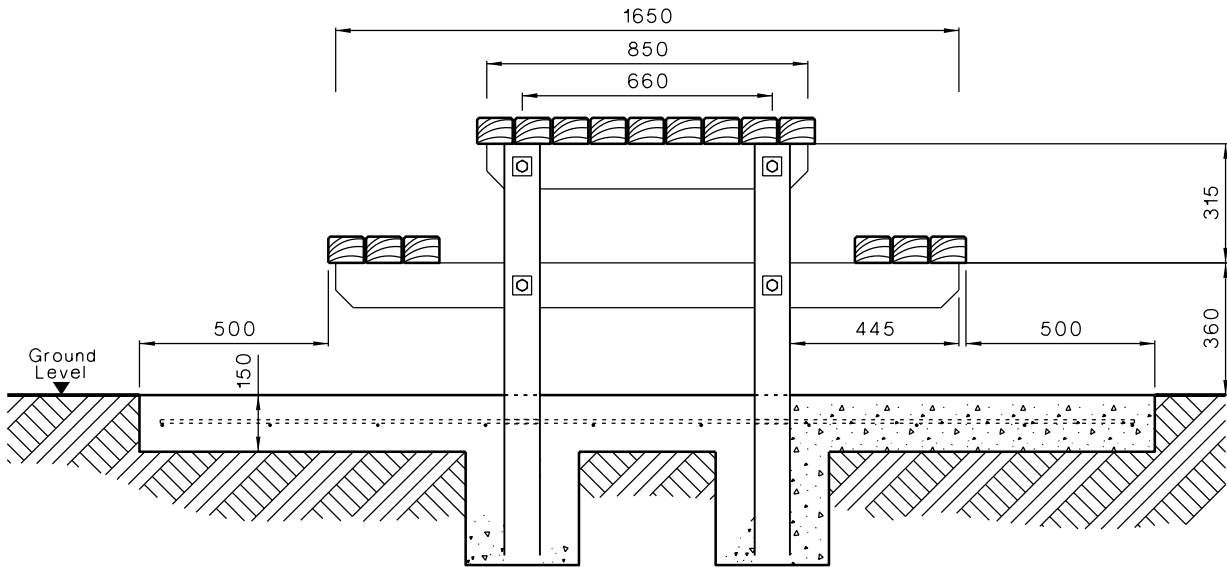

SIDE ELEVATION

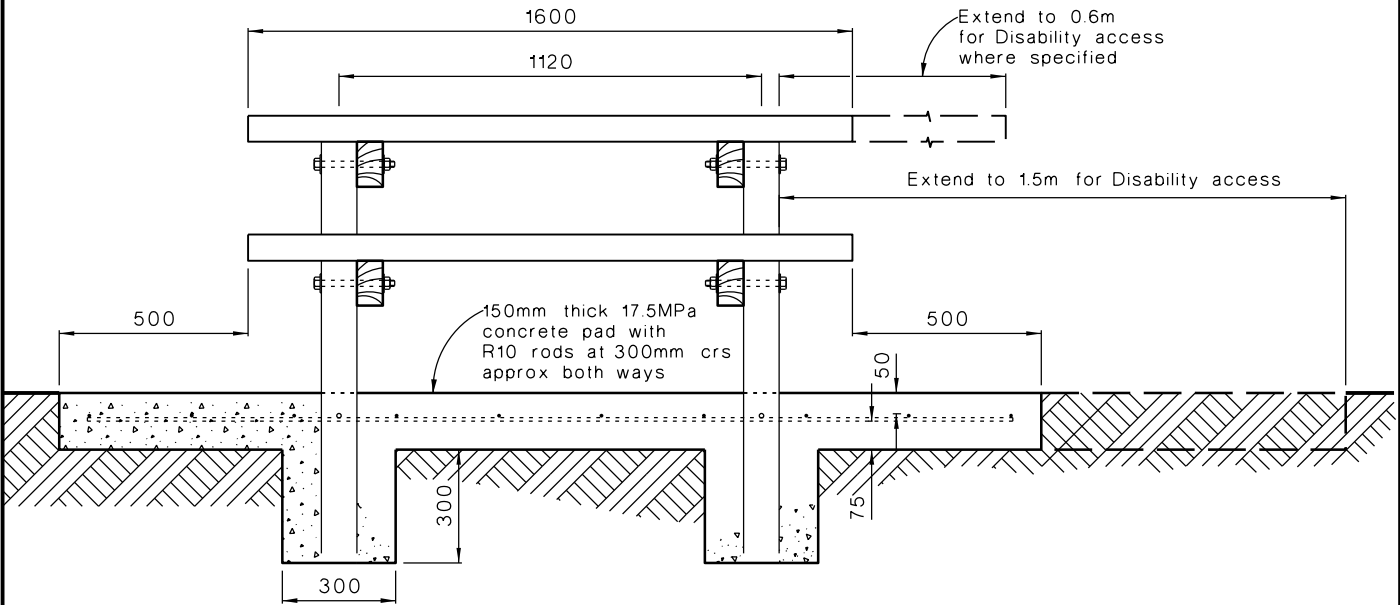

FRONT ELEVATION

Notes:

1. All timber to be H4 treated (non-corrosive type)
2. All timber to be gauged with the top and seat members to have 5mm chamfer to top edges
3. Top and seating timber to be from 100x75mm with 6mm gaps between
4. Supports to be from 125x75mm timber
5. Legs to be from 100x100mm timber
6. Bolts to be G.M.S. M16 with 50x50x3mm G.M.S. washer under both heads and nuts
7. Concrete slab to be 125mm thick 17.5MPa with R10 rods at 300mm crs approx both ways



Painting Specification:

E-Mac Drinking fountain colour to be Resene Karaka 1G015 unless otherwise specified.

Visible steel form work surfaces to be painted to the following specification:

- Surface preparation - Non-Ferrous Metals (Resene data sheet D89)
- 1st coat - Armourcote 510 (Resene data sheet RA40)
- 2nd coat - Vinyl Etch (Resene data sheet RA31)
- 3rd coat - \*Pigmented Uracryl 403 (Resene data sheet RA56)
- 4th coat - Clear Uracryl 403 (Resene data sheet RA56)

\*Colour to be Resene Karaka 1G015 unless otherwise specified.

All painting to be carried out to ensure no paint splashes & over runs occur on other surfaces.

Concrete top to have a U3 trowelled finish

Concrete base to be squared off if located next to a wall

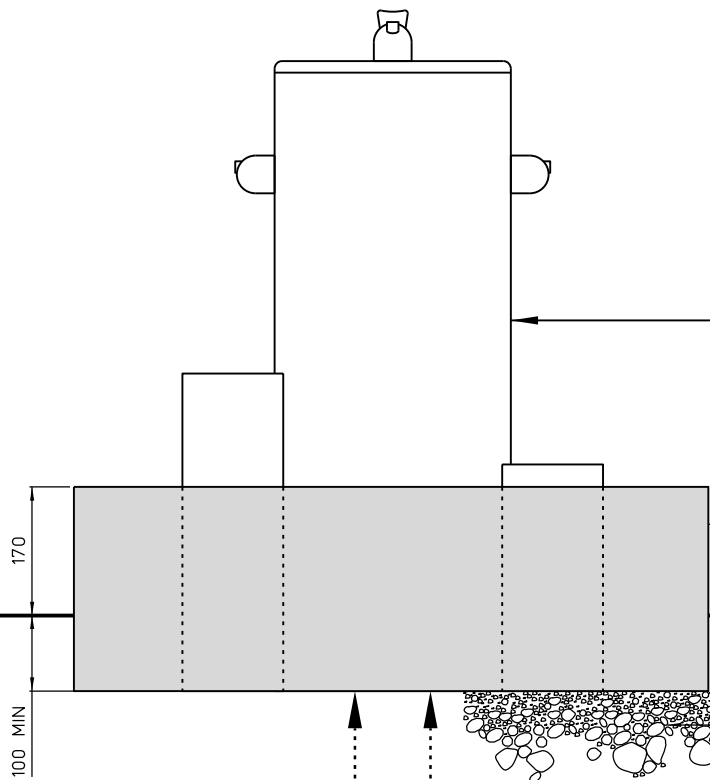
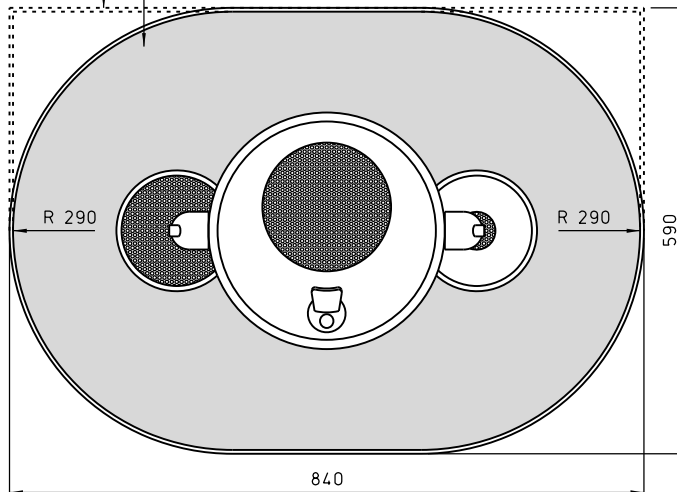

Drinking fountain to be supplied & installed by E-Mac Enterprises LTD. Ph (03) 377-3897

270x5mm steel form work (left insitu) with welds single bevel butt & ground flush. Hot dip galvanised after fabrication. concrete foundation to be 20MPa at 28 days

Ex. Ground level

Foundation to be seated on solid bearing material. Excavate & back fill with AP40 compacted in layers not exceeding 250mm thick as required.

12mm DIA MINIMUM COLD WATER FEED CENTRALLY PLACED IN BASE. TERMINATE AT GROUND LEVEL READY FOR E-MAC INDUSTRIES TO CONNECT TO DRINKING FOUNTAIN.

65mm DIA PVC WASTE CENTRALLY PLACED IN BASE. TERMINATE AT GROUND LEVEL READY FOR E-MAC INDUSTRIES TO CONNECT TO DRINKING FOUNTAIN.

# SPECIFICATION:

1. GALVANISING:
  - a. All steel fixings to be hot dip galvanised.
  - b. Supports shall be hot dip galvanised after fabrication, with all blow holes located so as not to allow water (rain/washing down) to enter the frame. Blowholes shall be located in non-visible locations wherever possible.
  - c. Hot dip galvanising shall be in accordance with NZS 4680.
  - d. All hot dip galvanising defects shall be repaired by hot zinc metal spray.
2. FOUNDATIONS:
  - a. Contractor to verify locations of all underground services before excavating.
3. TIMBER:
  - a. Timber seat slats to be from a sustainable source approved by CCC.
  - b. All timber to be seasoned and dried to a moisture content of between 12-16%

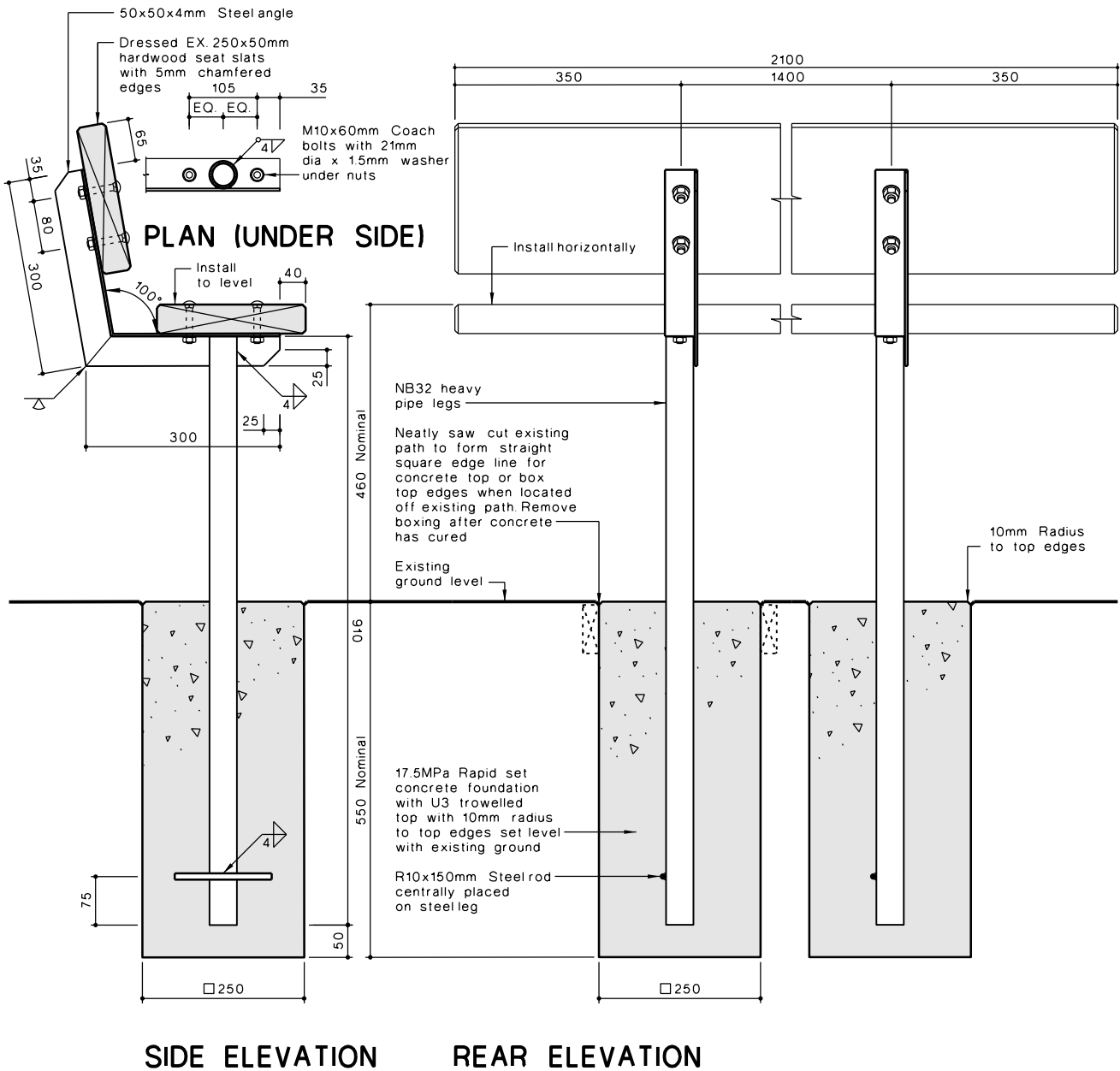

150x25mm H4 timber battens  
with 50x50x600mm H4 timber  
pegs at 1m crs max.

Peg 25mm below  
finished level

Adjacent grassed  
ground Level

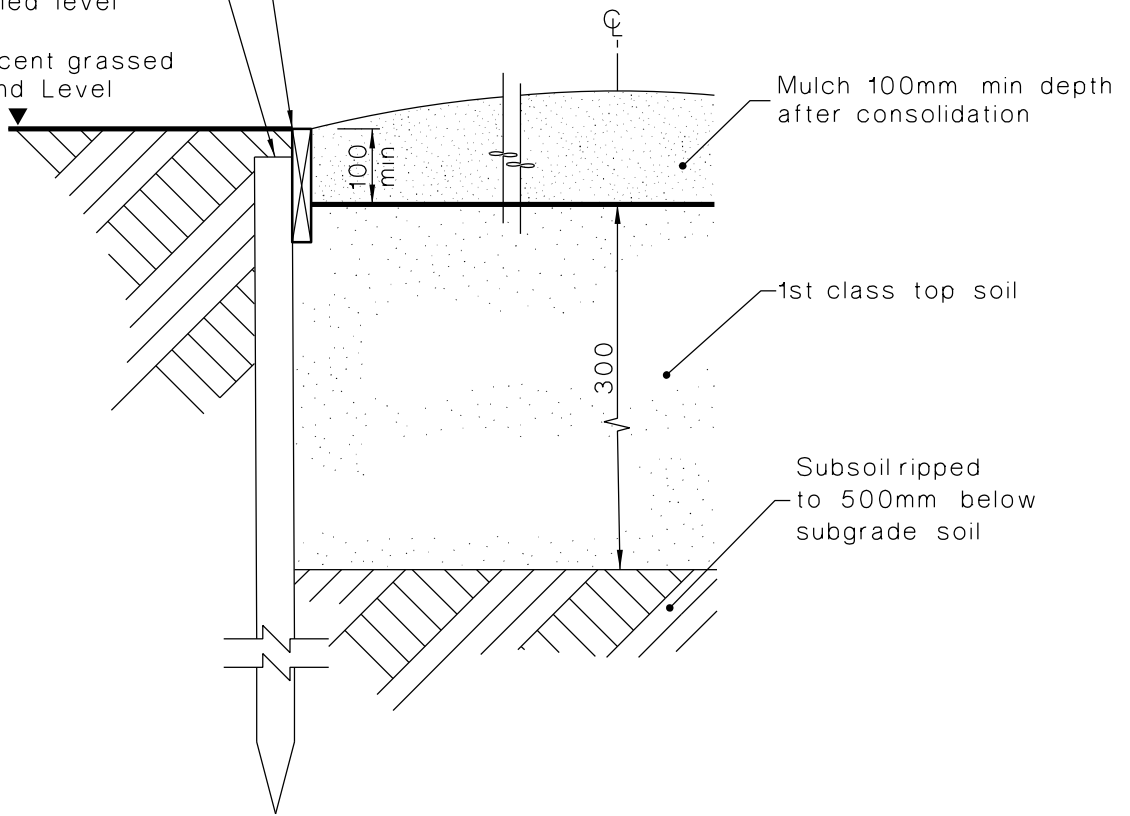

### BATTEN EDGE

Adjacent grassed  
ground Level

Smooth cut face  
top edge line  
to be straight

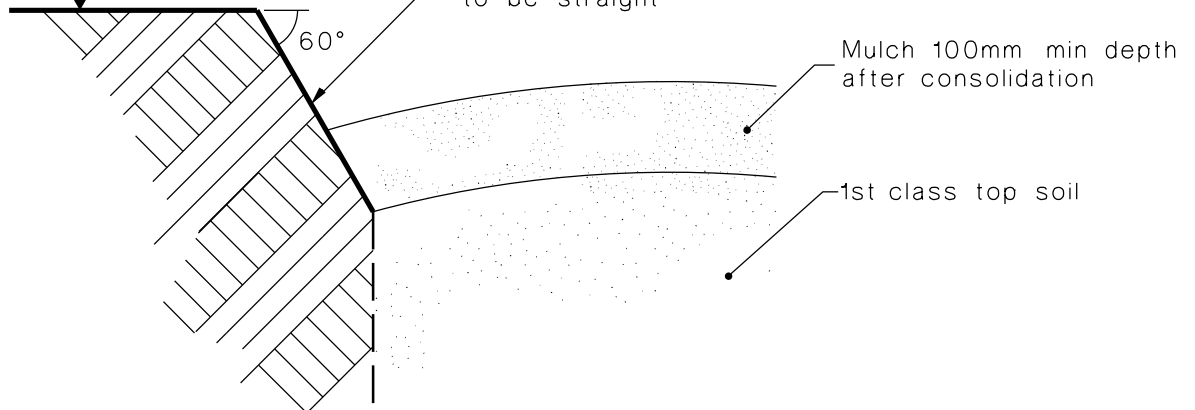

### CUT EDGE TO PLANT BED ADJACENT TO TURF

NOTES:

1. Refer to SD609 for plant bed/landscaping adjacent to footpath.

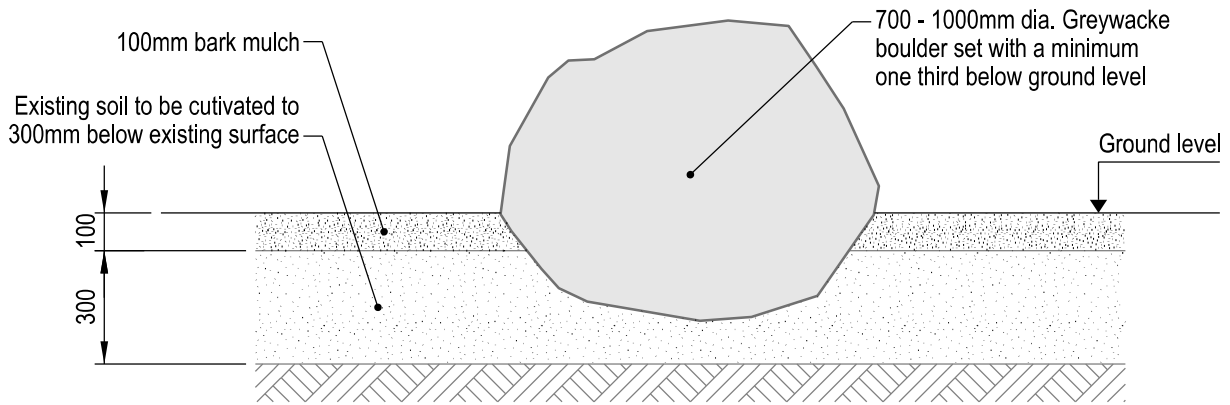

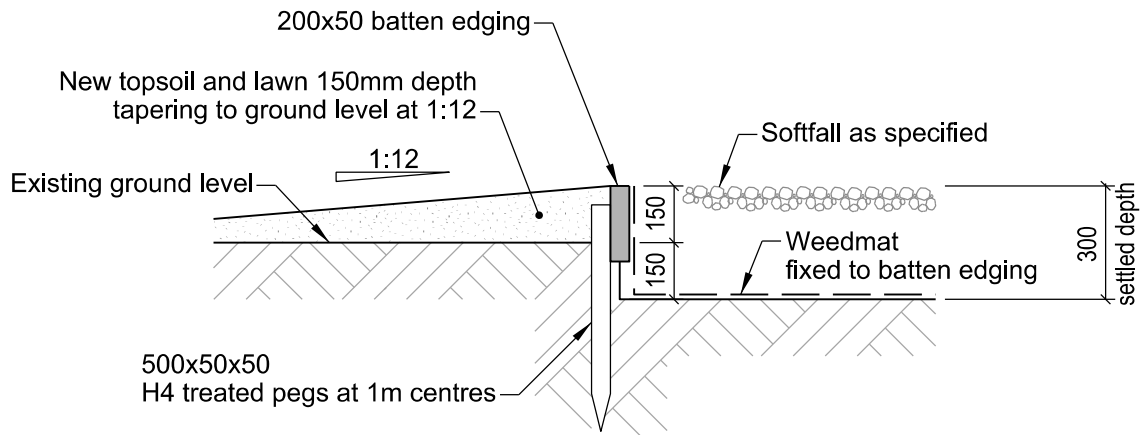

### IN-GROUND RETAINING EDGE

**NOTE:**

- 1) Replace edging with two 200x25mm battens where required to allow for curves.
- 2) Lawn may be replaced by a plant bed.
- 3) Refer to CSS Part 1 clause 17.3 when disposing of spoil offsite.

200x50mm H4 treated timber fixed to posts and edge batten with galvanised nails. Chamfer top edges to 5mm radius.

250x50mm H4 treated timber fixed to posts with M12 coach screws at 1m centres

200mm wide x 100mm deep concrete mowing strip

Existing ground level

100x100x550mm H4 treated pine posts at 1.0m intervals. Set post into concrete foundation at corners or every third post on straight runs.

50 x 25 batten nailed to side to hold weed mat in position

Softfall as specified

Weedmat

Grass / vegetation removed

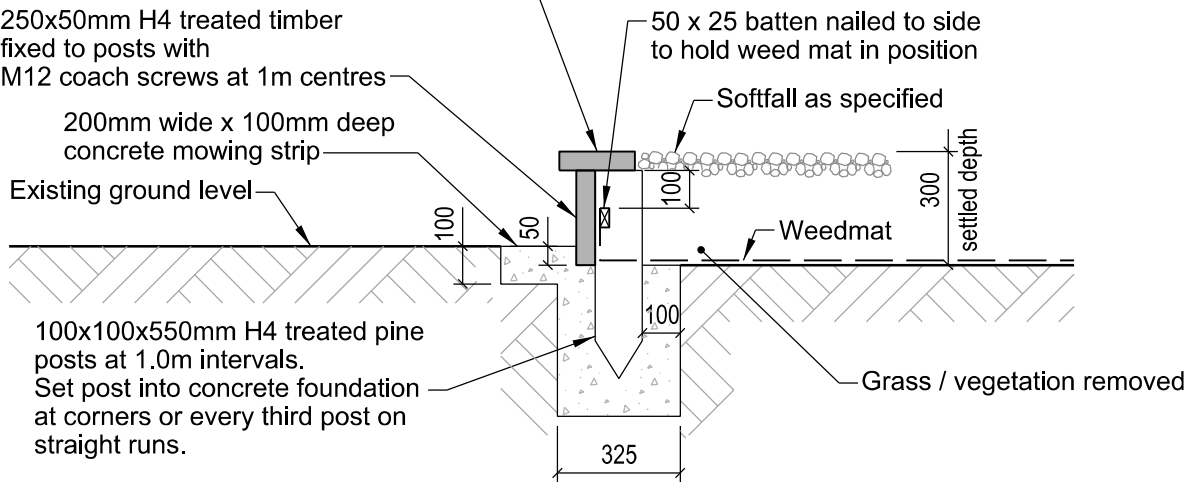

### TIMBER RETAINING EDGE

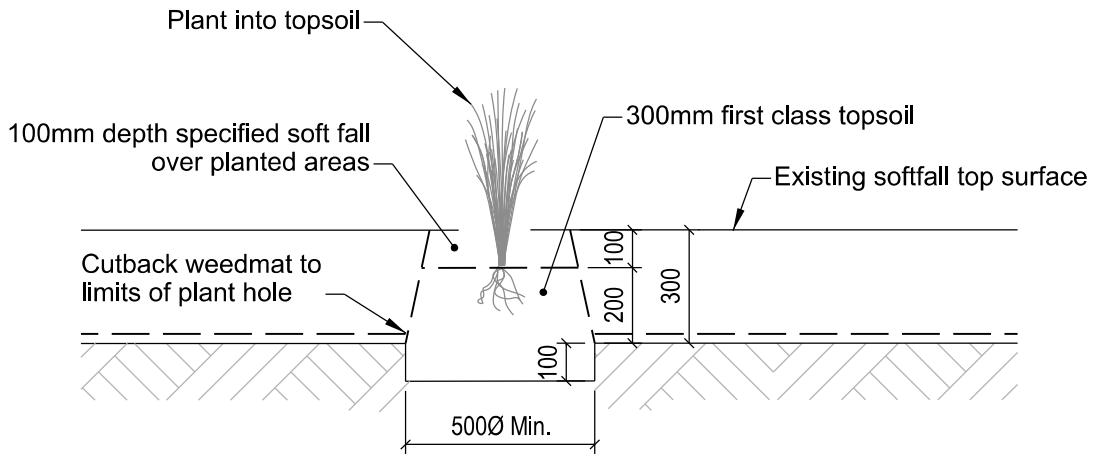

### PLANTING

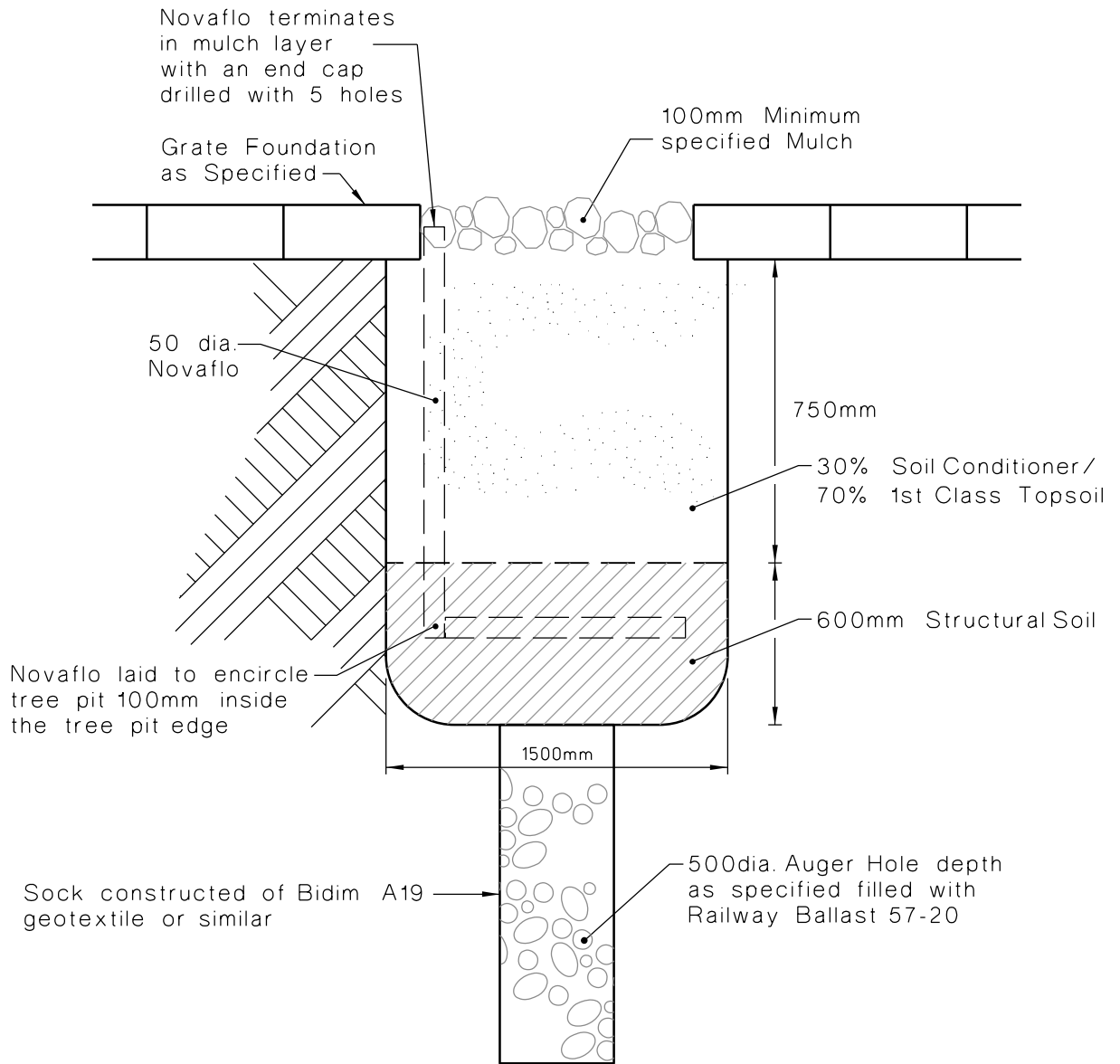

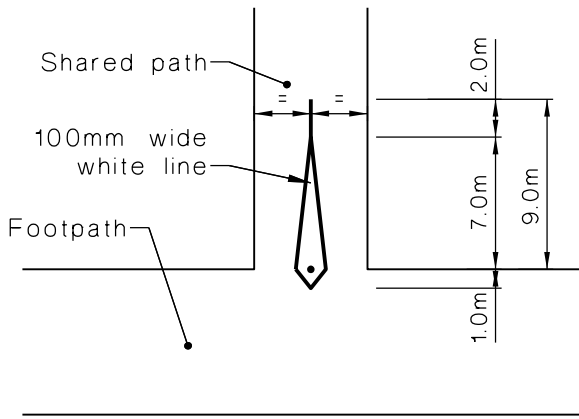

MARKING OF ENTRANCE AT FOOTPATH

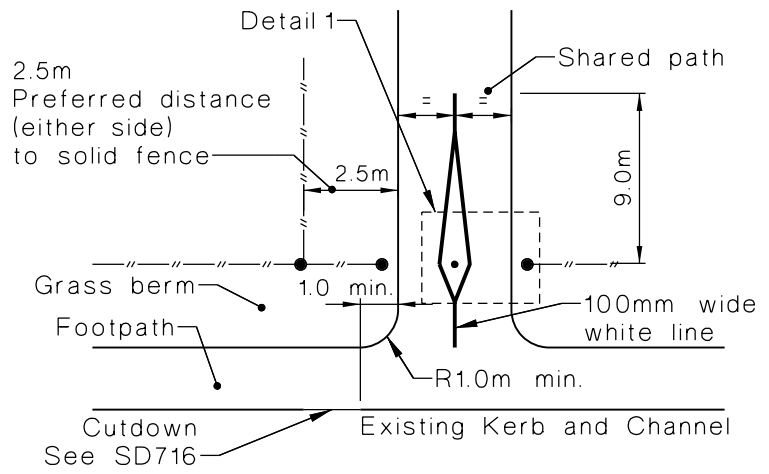

PLAN OF ENTRANCE SET BACK FROM FOOTPATH

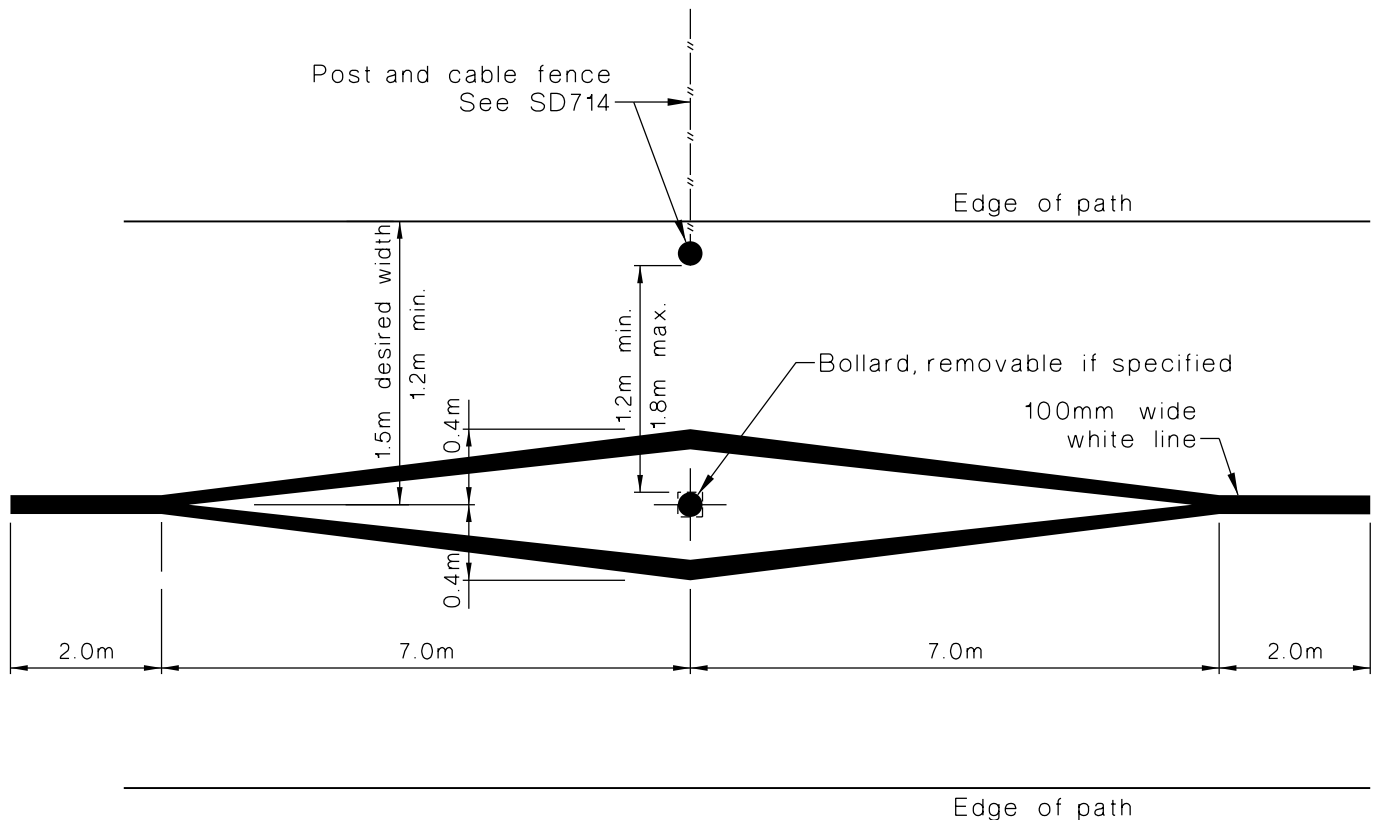

DETAIL 1

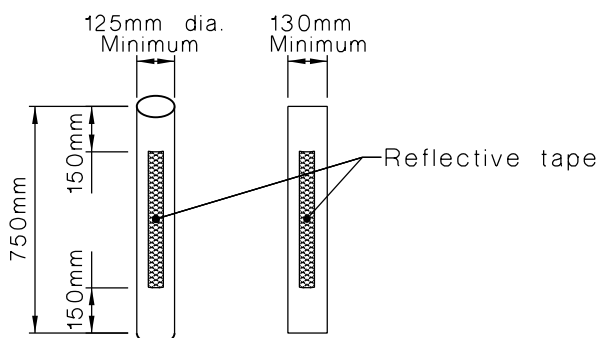

BOLLARDS

NOTES:

1. Use vandal resistant, weather resistant, low maintenance materials e.g. galv. steel, aluminium or H5 treated timber.
2. Square bollards should be used only where signs are to be attached to the bollard.
3. If Bollards are required to be removable, the method of fixing is to be approved by the Engineer.
4. Bollard colour to be traffic signal pole yellow.
5. Reflective tape to face direction of approach travel.



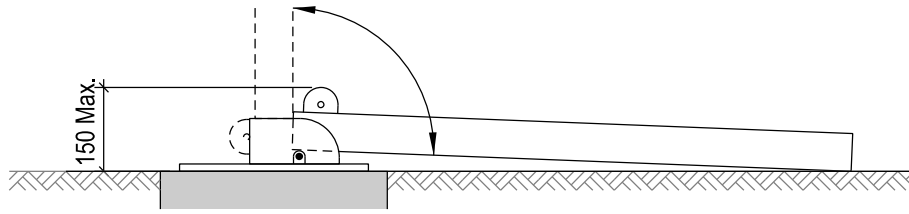

FOLDED DETAIL

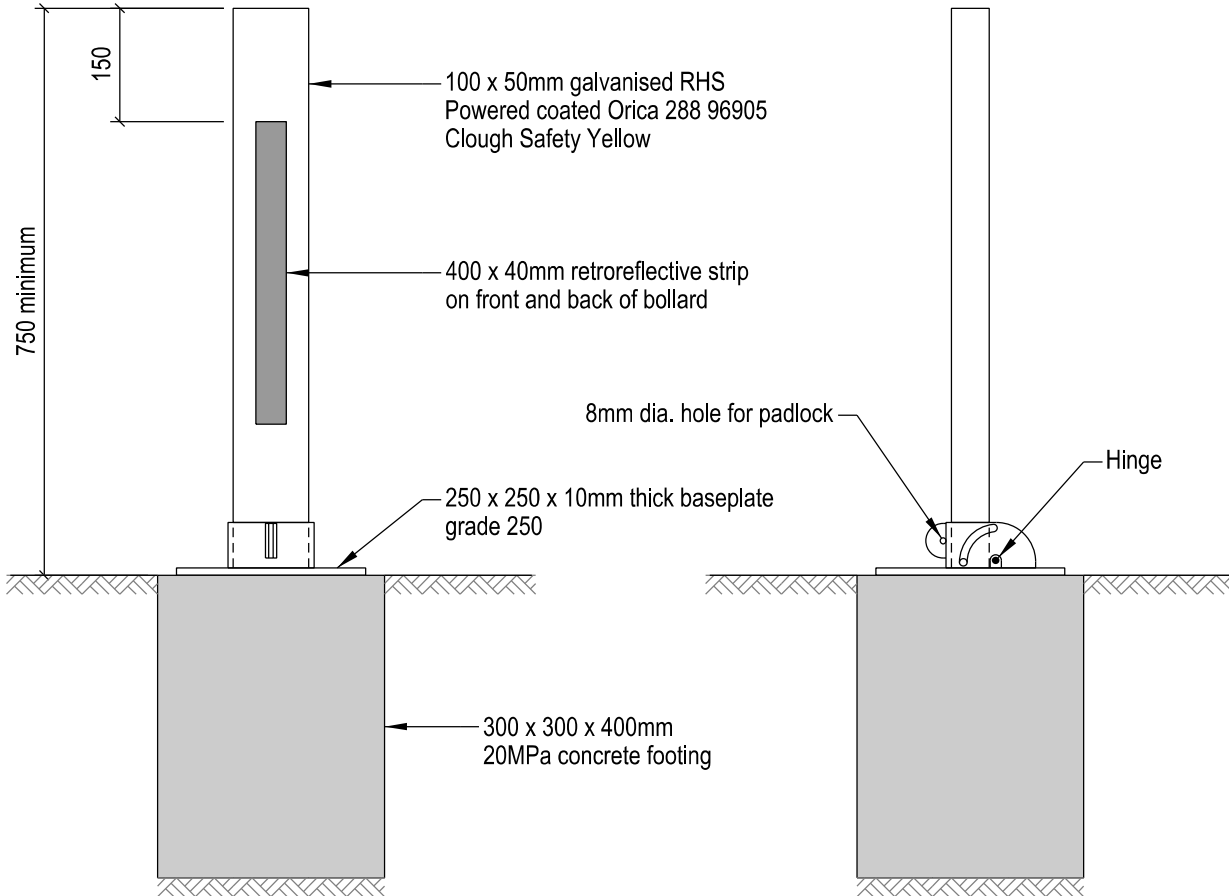

FRONT ELEVATION

SIDE ELEVATION

**NOTES:**

1. Fix baseplate to concrete footing with 4 x M16 ChemSet Anchors or similar.
2. Direction of hinge to be specified.

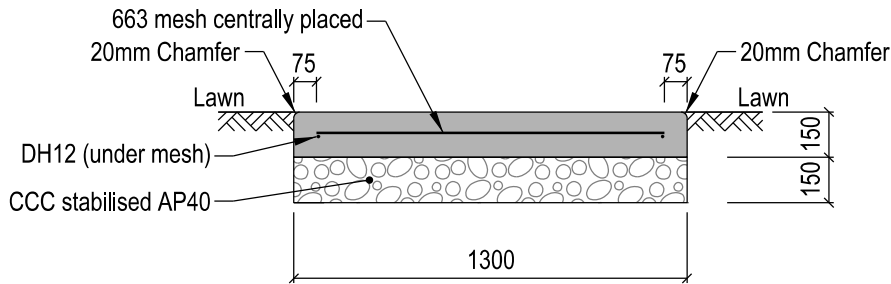
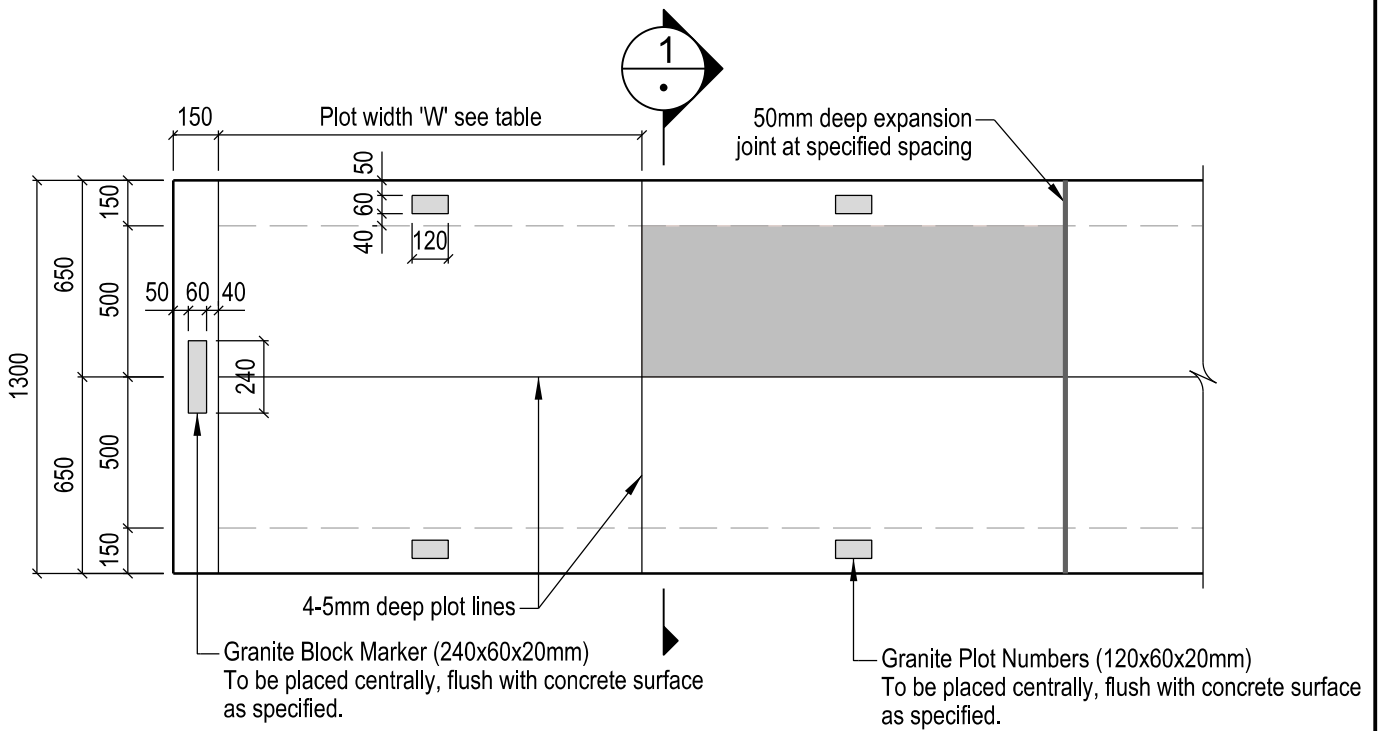

SECTION 1

**NOTES:**

1. All formwork is to be removed.
2. Granite plot numbers and block markers will be supplied by Council.

**Concrete**

3. All concrete work is to comply with the provisions of NZS 3109 and related documents.
4. Concrete strength to be 20Mpa (28 days).
5. All construction joints shall be type 'B' unless specified otherwise.
6. Even concrete textured roller finish to entire beam surface.
7. Concrete edging tool to be used on all edges.
8. Expansion joints to be 50mm deep and made in a straight line using a concrete (diamond) cutting blade.
9. All other plot lines are to be 4-5mm deep and made in a straight line using a concrete (diamond) cutting blade.

**Reinforcing**

10. All reinforcing shall be in accordance with NZS 3109 and related documents.
11. Cover to reinforcing to be 50mm unless otherwise shown.
12. Laps in reinforcing to be 300mm

Plot Type	Width	Expansion Joint Spacing
Full plot	1.4m	2.8m (every 2 plots)
Ash plot	0.6m	2.4m (every 4 plots)
Infant or quarter plot	0.6m	2.4m (every 4 plots)

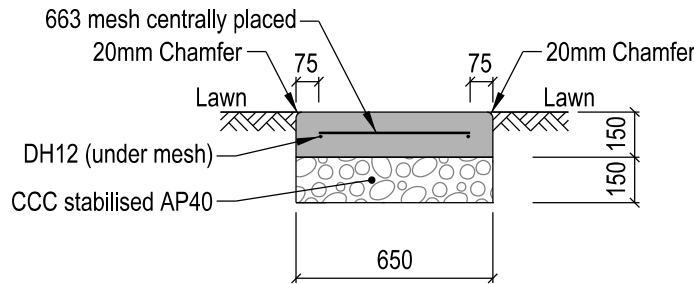
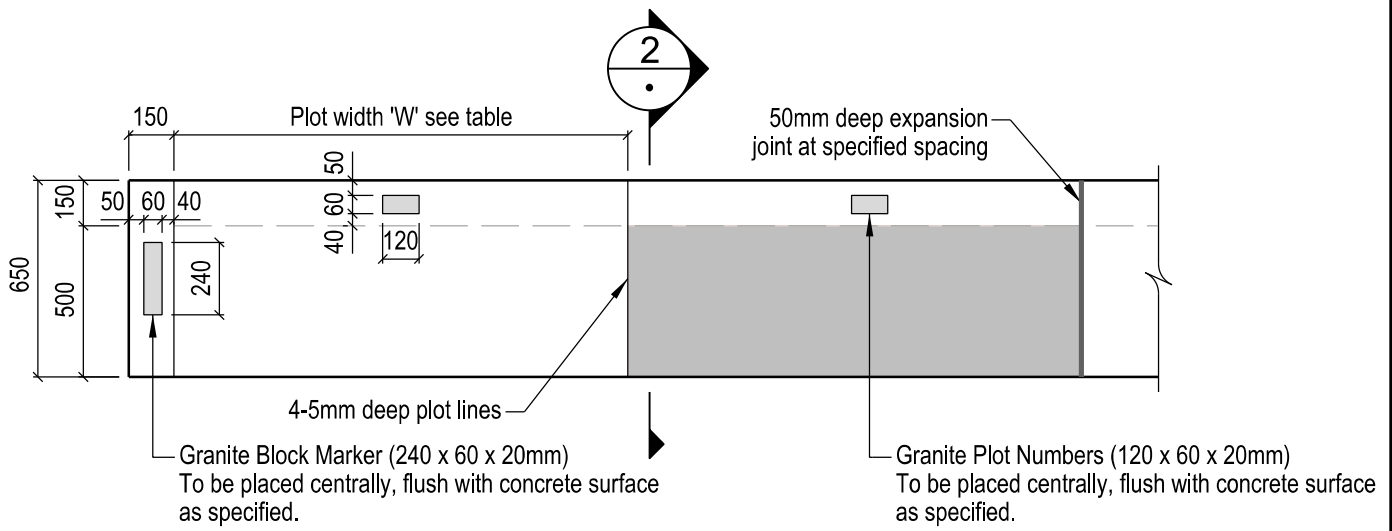

**NOTES:**

1. All formwork is to be removed.
2. Granite plot numbers and block markers will be supplied by Council.

**Concrete**

3. All concrete work is to comply with the provisions of NZS 3109 and related documents.
4. Concrete strength to be 20Mpa (28 days).
5. All construction joints shall be type 'B' unless specified otherwise.
6. Even concrete textured roller finish to entire beam surface.
7. Concrete edging tool to be used on all edges.
8. Expansion joints to be 50mm deep and made in a straight line using a concrete (diamond) cutting blade.
9. All other plot lines are to be 4-5mm deep and made in a straight line using a concrete (diamond) cutting blade.

**Reinforcing**

10. All reinforcing shall be in accordance with NZS 3109 and related documents.
11. Cover to reinforcing to be 50mm unless otherwise shown.
12. Laps in reinforcing to be 300mm

Plot Type	Width	Expansion Joint Spacing
Full plot	1.5m	3.0m (every 2 plots)
Quarter plot	0.75m	3.0m (every 4 plots)